

Seating blocks adjustable

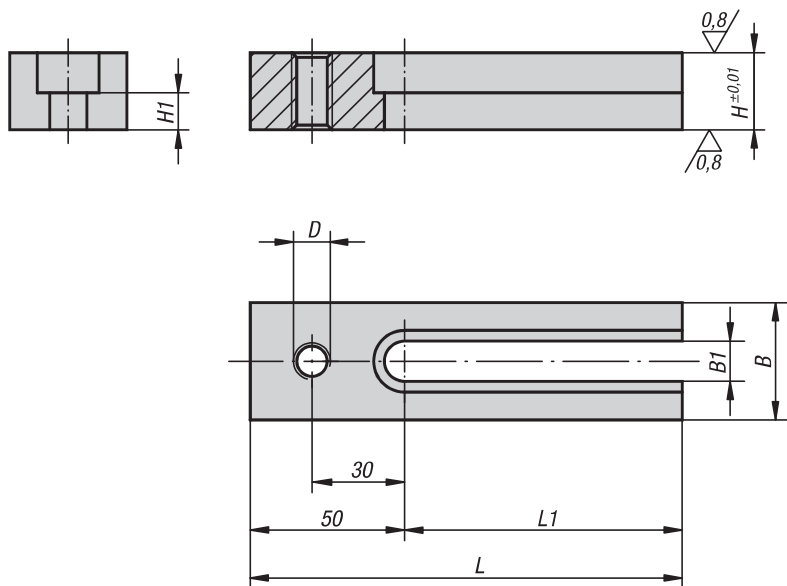

Material:
Carbon steel.

Version:
Tempered, black oxidised.
Contact faces ground.

Sample order:
K0824.12125

Note:
The tapped hole is for mounting fixture components.
The slot allows the riser to be set in any desired position.

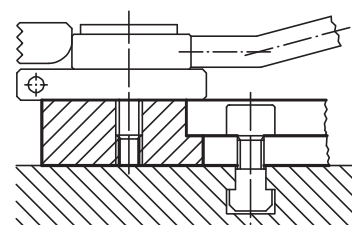

KIPP Seating blocks adjustable

Order No.	D	L	L1	B	B1	H	H1
K0824.12025	M12	90	40	38	13	25	12
K0824.12032	M12	90	40	38	13	32	19
K0824.12040	M12	90	40	38	13	40	27
K0824.12050	M12	90	40	38	13	50	37
K0824.12125	M12	140	90	38	13	25	12
K0824.12132	M12	140	90	38	13	32	19
K0824.12140	M12	140	90	38	13	40	27
K0824.12150	M12	140	90	38	13	50	37
K0824.16032	M16	90	40	50	17	32	15
K0824.16040	M16	90	40	50	17	40	23
K0824.16050	M16	90	40	50	17	50	33
K0824.16132	M16	140	90	50	17	32	15
K0824.16140	M16	140	90	50	17	40	23
K0824.16150	M16	140	90	50	17	50	33



Material:
Steel.

Version:
Case-hardened, black oxidised and ground

Sample order:
K0889.006

Note:
These supports are placed under long or thin workpieces to prevent vibration or bending during milling, drilling, grinding or shaping operations.

Drawing reference:
1) set screw

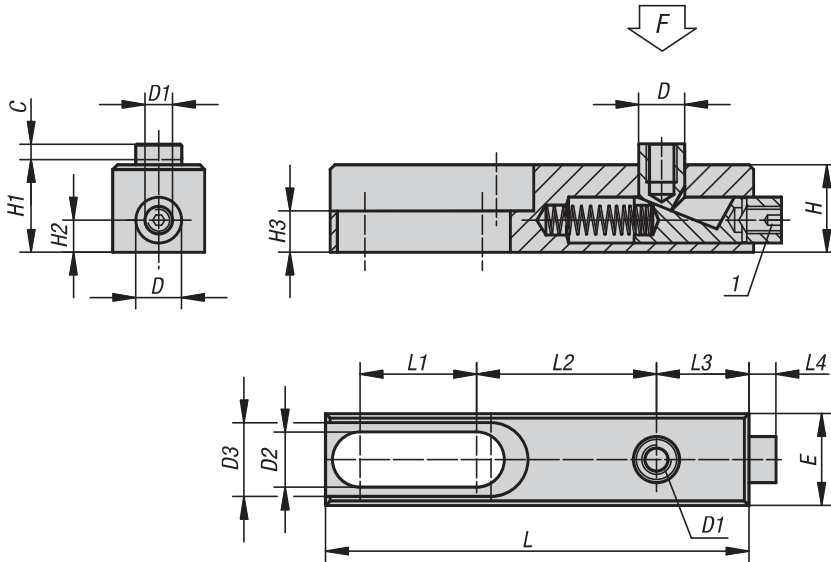

KIPP Workpiece supports

Order No.	C	D	D1	D2	D3	E	H	H1	H2	H3	L	L1	L2	L3	L4	F kN
K0889.006	4	10	M6	8,2	16,2	20	19	19,5	7	9	92	25,5	39	20	6	3
K0889.010	6	16	M10	12,5	24,4	30	30	31	10	10	149	44	61	32	11	15