

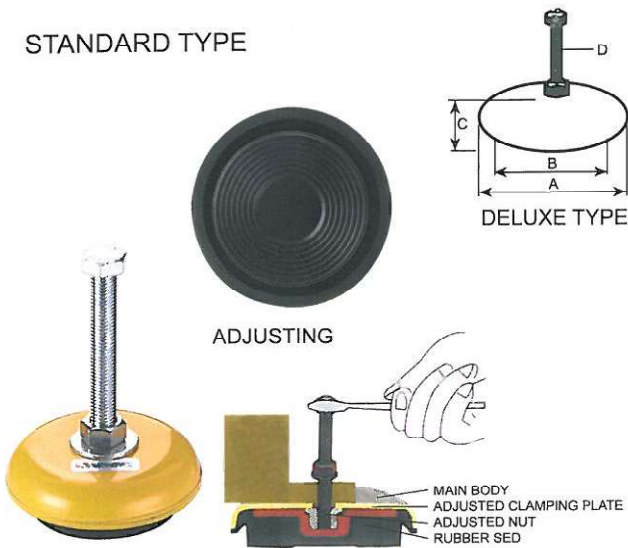

## STANDARD TYPE



## Special Features

Preventing shock & reducing noise. low bed design.  
Easy installation. Simple adjustment. High durability.

## Application

Various general working machines, metal work piece processing machine, production machine, special machine, measuring equipment, testing machine.  
Electrical generator, air compressor, etc.  
ADJUSTABLE RANGE 6-12 mm

Unit:mm

ORDER NO.	A	B	C	Ø DxL	LOAD KGS	Adjustable HEIGH	WEIGHT KGS	CODE NO.
TK-90	90	50	32	12M-100	500kg	5 mm	0.8	7001-000
TK-120	120	90	35	12M-100	1000kg	5 mm	1.4	7001-001
TK-160	160	130	38	16M-110	1500kg	6 mm	2.8	7001-002
TK-200	200	170	45	20M-120	3500kg	6 mm	4.4	7001-003

Features : Easy to operate. shock-absorbent, reduces machine noise includes adjustment, and assures production accuracy.

## DELUXE TYPE

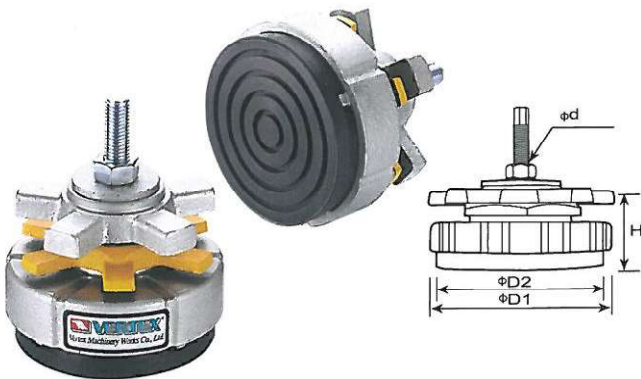

Unit:mm

ORDER NO.	D1	D2	H	Ø dxL	LOAD KGS	Adjustable HEIGH	N.W. KGS	CODE NO.
SB-4	100	90	60	12x50	500	25	2	7001-031
SB-6	150	135	95	16x110	1000	40	5	7001-032
SB-8	200	180	100	20x120	2500	40	8	7001-033
SB-10	250	230	125	24x180	4000	40	12	7001-034

SUITABLE FOR : machine tools, molding machine, printing machine, CNC lathe, grinding machines, drilling machines, milling machines.

- FCD45

## HEAVY DUTY TYPE

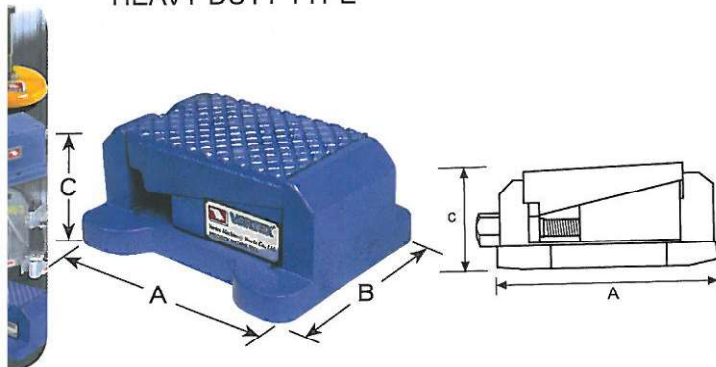

Unit:mm

ORDER NO.	A	B	C	LOAD KGS	Adjustable HEIGH	N.W. KGS	CODE NO.
SC-1	130	96	66	700	4MM	4	7001-060
SC-2	174	143	80	1500	5MM	8.8	7001-061
SC-3	217	165	101	2500	6MM	16	7001-062

SUITABLE FOR : CNC lathe, milling machines, cutting machines, grinding machines.

- FCD45

## LIGHT DUTY TYPE

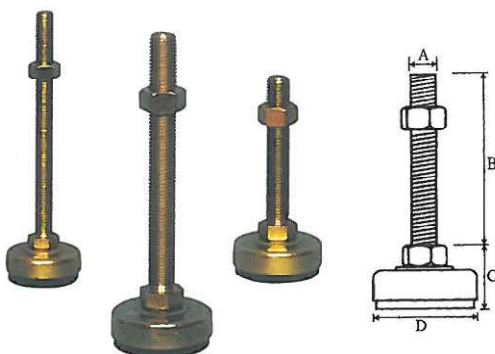

Unit:mm

ORDER NO.	A	B	C	D	LOAD KGS	N.W. KGS	CODE NO.
SY-8	M8X1.25P	50	20	40	100	0.074	7001-080
SY-12	M12X1.25P	75	30	50	200	0.18	7001-081
SY-16	M16X2.0P	100	35	60	300	0.38	7001-082

- SS41



**NEW**

FRON 20 KN TO 225 KN

## Machine Stand

- Leveling
- Reduce Vibration
- Increase Stability
- Frictionless
- Precision & Accurate
- Rubber : 80°, 5mm Thickness

### STEP

- Place shock absorbers under machine.
- When shock absorbers have full contact with machine base, you can start to adjust the leveling.

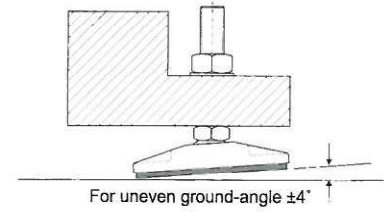
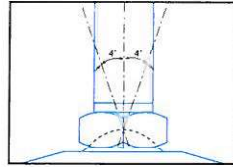
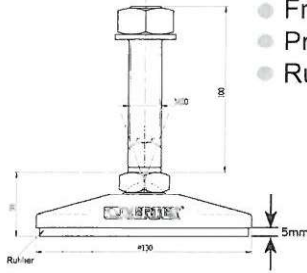

ORDER NO.	L x W x H	THREAD	LOAD KGS	UNEVEN GROUND-ANGLE	WEIGHT KGS	CODE NO.
VSA-25K	130 x 39 x 139	M20 x 100L	2200	± 4°	1.76	7001-140

**NEW**



VSA-35K-6RU

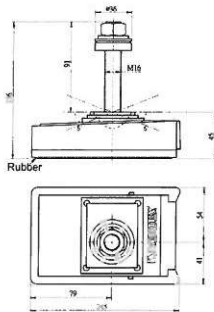

- Leveling
- Reduce Vibration
- Increase Stability
- Frictionless
- Precision & Accurate

### STEP

- Place shock absorbers under machine.
- When shock absorbers have full contact with machine base, you can start to adjust the leveling.



VSA-35K

Adjustable screw

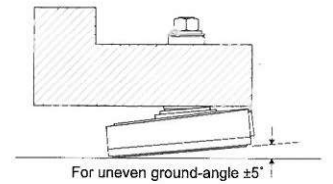
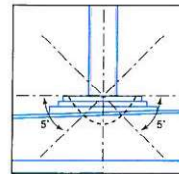
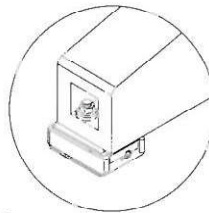

ORDER NO.	L x W x H	THREAD	LOAD KGS	UNEVEN GROUND ANGLE	RUBBER	ADJUSTMENT HEIGHT / FROM ADJUSTABLE SCREW	WEIGHT KGS	CODE NO.
VSA-35K	145 x 95 x 136	M16 x 91L	6300	±5°	2 m/m x 80° shore	7 mm	1.61	7001-160
VSA-35K-6RU	145 x 95 x 140	M16 x 91L	6300	±5°	6 m/m x 90° shore	7 mm	1.61	7001-161

**NEW**



VSA-35K-PS-BL



VSA-35K-PS



ORDER NO.	L x W x H	ADJ. THREAD LENGTH	LOAD KGS	UNEVEN GROUND ANGLE	RUBBER	ADJUSTMENT HEIGHT / FROM ADJUSTABLE SCREW	WEIGHT KGS	CODE NO.
VSA-35K-PS	145 x 95 x 134	M16 x 91L	6300	±5°		7 mm	1.4	7001-162
VSA-35K-PS-BL	145 x 95 x 144	M16 x 81L	6300	±5°		7 mm	1.4	7001-163





# Shock Absorber Heavy Duty



**NEW**



VSA-150H

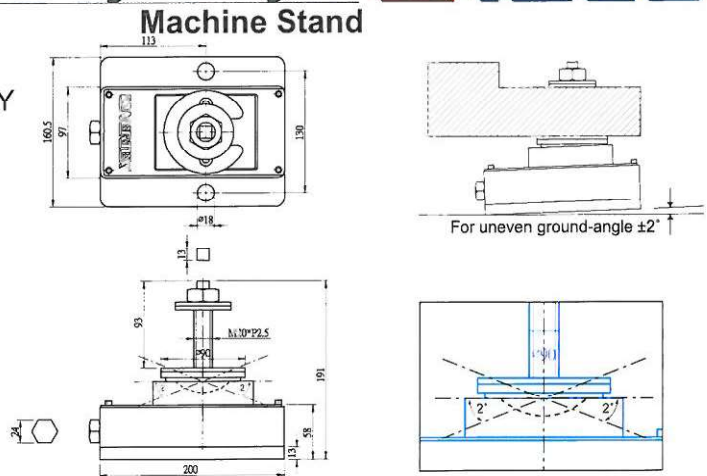

- Leveling
- Reduce Vibration
- Increase Stability
- Frictionless
- Precision & Accurate

### STEP

- Place shock absorbers under machine.
- When shock absorbers have full contact with machine base, you can start to adjust the leveling.

ORDER NO.	L x W x H	THREAD	LOAD KGS	UNEVEN GROUND-ANGLE	ADJUSTMENT HEIGHT / FROM ADJUSTABLE SCREW	WEIGHT KGS	CODE NO.
VSA-150K	200 x 160.5 x 91	M20 x 93L	22500	± 2°	7 mm	9.32	7001-180
VSA-150H	200 x 160.5 x 182	M20 x 84L	22500	± 2°	7 mm	9.32	7001-190



# Arbor Press

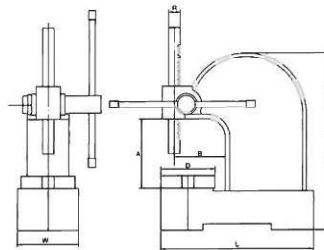

### STANDARD TYPE

- All main parts made of ductile cast iron. Adjustable handle gives convenient handle positioning.
- Ram finite control by smooth gears.
- 4-90 degree equally divided slotted round table.
- Color may vary. (Green)

ORDER NO.	Base LxW(mm)	Height H(mm)	MAX Work Height A(mm) Stroke	Swing B	Table Diameter D	Ram Dimension RxR	Weight (kgs)	CODE NO.
VAR-0	235x102mm	254	114	85	90	19x19	8.5	7002-100
VAR-1	270x127mm	320	140	105	110	25.4x25.4	12	7002-101
VAR-2	400x170mm	445	215	135	170	31.7x31.7	29	7002-102
VAR-3	470x200mm	570	317	135	170	38.1x38.1	47	7002-103
VAR-5	680x250mm	800	470	245	250	50.8x50.8	140	7002-104

### RATCHET LEVERS TYPE

This arbor press with all standard's feature. But operated with a ratchet device that will allow you to use the lever in the most convenient position, the lever has a counterweight for quick return after which the down stroke handwheel will return the ram to the work quickly.

- Ratchet Type Arbor Press available-No. 3/5 only. The size is same as VAR-3, 5 Color may be varied. (Green)



ORDER NO.	VARR-3	VARR-5
G.W. KGS	65 kgs	162 kgs
CODE NO.	7002-131	7002-132