



HEINRICH KIPP WERK



# ZERO POINT Clamping Technology

Edition 09 2018



# CONTENTS

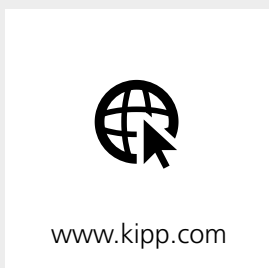
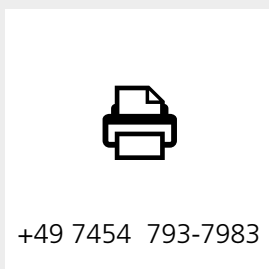
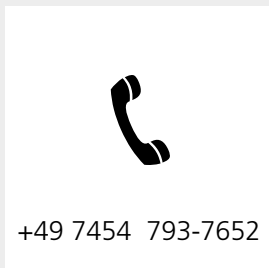

## PRODUCT OVERVIEW 4

---

### Zero-point clamping system

Technical Information	10
Products	12
Applications	24

---

### 5-axis module clamping system 80

Function	28
Setup times / Interfaces	30
Forces	32
Applications	33
Products	36

---

### 5-axis module clamping system 50

Forces	56
Function	57
Products	58
Applications	65

---

### 5-axis module clamping system 138

Forces	69
Products	70

---

### Locating and clamping system

General information	78, 83
Products	79

---



Reg. Nr. 002081 QM



## SERVICE HOURS (CET)

MONDAY-THURSDAY	7.00 am - 5.30 pm
FRIDAY	7.00 am - 3.30 pm

## Zero-point clamping system



Interchangeable subplates  
for UNI lock zero-point  
clamping system  
**K1218**



Page 19

UNI lock clamping pin  
size 80 mm  
**K0967**



Page 20

UNI lock clamping station  
**K1009**



Page 12

Protective bolt  
for clamping module  
**K1010**



Page 22

UNI lock clamping station  
**K1009**



Page 13

Protective plug  
for clamping module  
**K1010**



Page 22

UNI lock installation clamp  
**K1003**



Page 14

Quick-fit couplings  
**K1011**



Page 23

UNI lock installation clamp  
**K1385**



Page 15

UNI lock mounting clamps  
**K1389**



Page 16

UNI lock double clamping module  
**K1122**



Page 17

UNI lock manual clamping module  
**K1123**



Page 18



## 5-axis module clamping system 80



UNI lock 5-axis reducer adapter  
size 80 mm  
**K0966**



Page 43

Angle clamp adapters  
size 80 mm  
**K1013**



Page 44

UNI lock 5-axis basic module  
system size 80 mm  
**K0960**



Page 36

UNI lock 5-axis basic module double  
clamp size 80 mm  
**K0961**



Page 37

UNI lock 5-axis base plate  
for general clamping,  
system size 80 mm  
**K0962**



Page 38

UNI lock 5-axis add-on clamping  
module size 80 mm  
**K0963**



Page 39

UNI lock 5-axis collet adapter  
size 80 mm  
**K0964**



Page 40

UNI lock 5-axis face-grip adapter  
size 80 mm  
**K0965**



Page 41

UNI lock 5-axis reducer adapter  
size 80 mm  
**K0966**



Page 42

UNI lock T-slot centring clamp bolt  
size 80 mm  
**K0969**



Page 45

UNI lock clamping pin  
size 80 mm  
**K0967**



Page 46

UNI lock clamping pin  
one-piece size 80 mm  
with threaded pin size 80 mm  
**K0967**



Page 48, 49

UNI lock clamping bolts for  
fastening to workpieces  
size 80 mm  
**K0968**



Page 50

UNI lock 5-axis shoulder screws  
size 80 mm  
**K0970**



Page 50

UNI lock 5-axis shoulder screws  
for fastening to workpieces  
size 80 mm  
**K0971**



Page 51

Centring clamping bolts  
size 80 mm  
**K1012**



Page 52

## 5-axis module clamping system 50



UNI lock 5-axis basic module  
system size 50 mm  
**K1117**



Page 58

UNI lock 5-axis basic module  
adjustable  
system size 50 mm  
**K1117**



Page 59

UNI lock 5-axis basic module  
double clamp  
system size 50 mm  
**K1118**



Page 60

UNI lock 5-axis add-on module  
system size 50 mm  
**K1119**



Page 61

UNI lock 5-axis add-on module  
adjustable  
system size 50 mm  
**K1119**



Page 62

UNI lock 5-axis reducer adapter  
system size 50 mm  
**K1120**



Page 63

UNI lock clamping pin  
system size 50 mm  
**K1121**



Page 64

## 5-axis module clamping system 138



UNI lock 5-axis basic module  
system size 138 mm  
**K1419**



Page 70

UNI lock 5-axis baseplate  
for general clamping,  
size 138 mm  
**K1420**



Page 71

UNI lock 5-axis reducer adapter  
system size 138 mm  
**K1422**



Page 72

UNI lock 5-axis reducer adapter  
system size 138 mm  
**K1423**



Page 73

UNI lock clamping pin  
system size 138 mm  
**K1424**



Page 74



## Locating and clamping systems



Locating cylinder  
Ball Lock  
**K0935**



Page 79

Locating cylinder  
with quick clamping system  
**K0935**



Page 80

Centring bushes  
**K0936**



Page 81

Receiver bushes  
Form A (pressed in from rear)  
**K0937**



Page 82

Receiver bushes  
Form B (screwed down from front)  
**K0938**



Page 82

Locating cylinders  
pneumatic  
**K1219**



Page 83

Locating bushes  
for pneumatic locating cylinder  
**K1220**



Page 84





## Zero-point clamping system



# Technical information zero-point clamping system



## Application

The modular structured flexible zero-point clamping system was specifically developed for the machining and non-machining fields.

This system enables a quick and accurate clamping and referencing of fixtures and workpieces on all production machines, machining centres, EDM's and inspection equipment.

Whether subplate, fixture, vice or workpiece, this system allows an exchange with a defined reference point in a matter of seconds and repeat accuracy of less than 0.005 mm.

## The advantages

- Modular system
- Compact flat design
- Workpiece or fixture change within seconds
- Pneumatic system
- Positive locking
- Holding forces up to 75 kN and pull-in forces up to 15 kN
- Turbo function
- Positioning via short conical locator
- Works reliably in every mounting position
- Sealing air function

## Your benefit

- Can be combined with our modular clamping system
- Better machine room utilisation
- Increased productive machine running times, significantly reduced set-up times
- Reliable system
- Very high cutting forces possible
- High operating and process safety
- Increased pull-in forces are standard
- Very high repeat accuracy
- Clamping cylinder installation in both vertical and horizontal positions
- Blow out function can be activated when changing pallets



# Technical information zero-point clamping system



## Spigot arrangement/set-up

The workpieces, fixtures or subplates are positioned and clamped using spigots. There are three different spigot types.

- Centring spigot      fixed in x and y direction (reference point)
- Compensating pin      fixes the free axis (studs)
- Clamping spigot      Spigot with undersize (no centring function only clamping function)
- Cylindrical pin      For individual clamping, positioning is done with centring spigot + 2 cylindrical pins

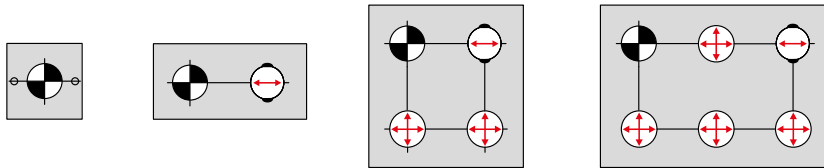

- 1 = fastening with grub screw DIN 913
- 2 = fastening with DIN 912 screw through the tightening bolt
- 3 = fastening with DIN 912 screw through the fixture or workpiece

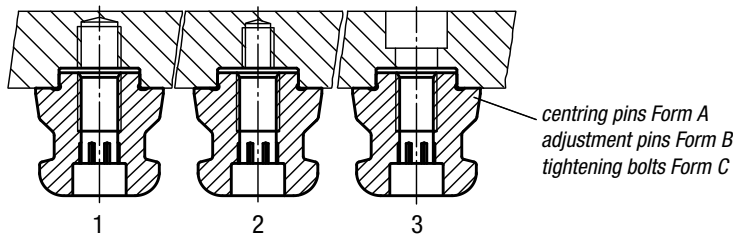

## The function

The proven UNI lock clamping module was made even flatter due to a new mechanism. The built-in toggle system together with guided clamping slides ensures high process reliability of the system.

## Toggle lever mechanism

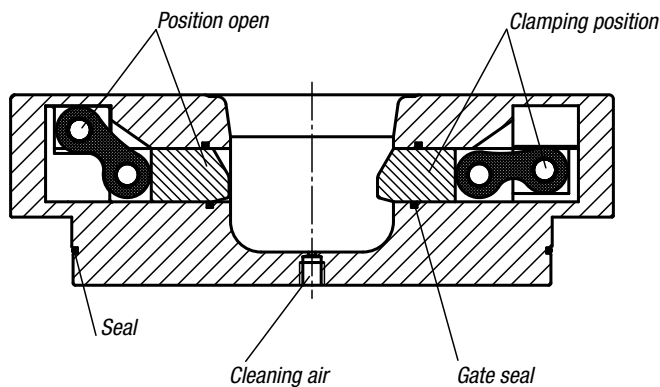

## UNI lock clamping station



1x

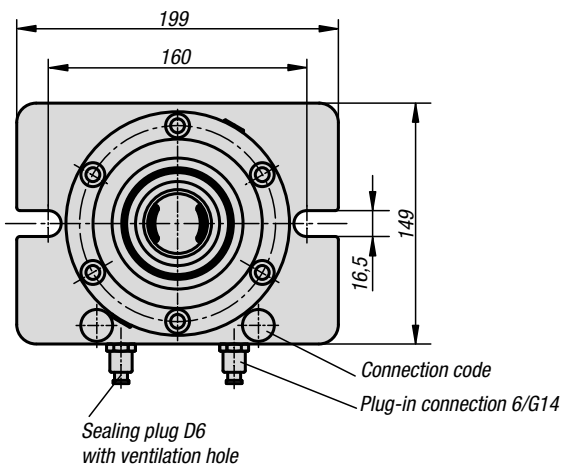
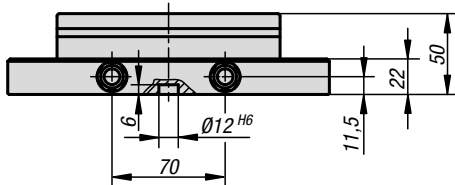

2x

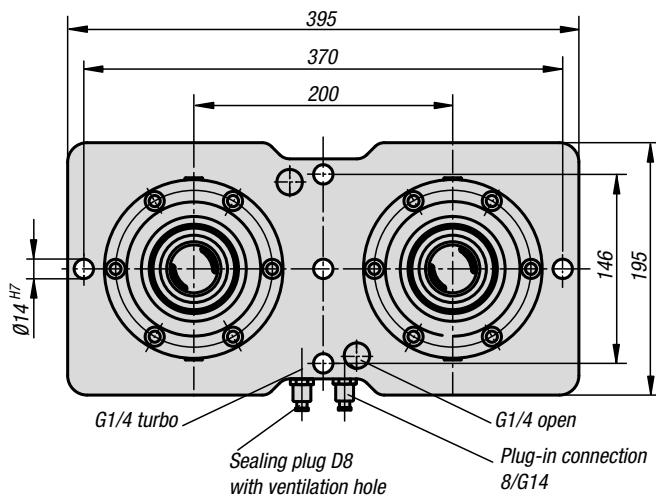
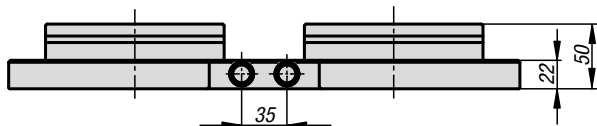

**Material:**

Clamping module mild steel.  
Base plate steel 1.1730.

**Version:**

Clamping module contact surfaces case-hardened and ground.  
Base plate ground on both sides.

**Sample order:**

K1009.1000149199

**Note:**

Completely mounted multi-clamping stations with integrated UNI lock Ø138 mm mounting clamps. The clamping stations are secured to the machine table directly or with clamps. Common bore patterns are pre-centred on the rear side for mounting. Clamping stations can be aligned via the 14H7 reference holes. The clamping stations are actuated via a central pneumatic connection. The high clamping forces are generated by the integrated spring package (the unit clamps in the de-pressurized state). The release process occurs pneumatically.

The following retaining forces are possible with the UNI lock clamping bolt in conjunction with mounting screws M10, M12, M16.

- Retaining force (M10) 35,000N/module
- Retaining force (M12) 50,000N/module
- Retaining force (M16) 75,000N/module

**On request:**

Clamping station in special dimensions.

**Technical data:**

- Opening pressure: 6bar, lubricated air
- Turbo pressure: 6bar
- Air connection: G1/4
- Repeat accuracy ≤ 0.005 mm
- Reference holes 14H7 to align the clamping plate.
- Pneumatic connectors for 6 mm pneumatic hose.

### KIPP UNI lock clamping station

Order No.	Type	weight kg
K1009.1000149199	1x	7.08
K1009.2200395195	2x	17.681

## UNI lock clamping station

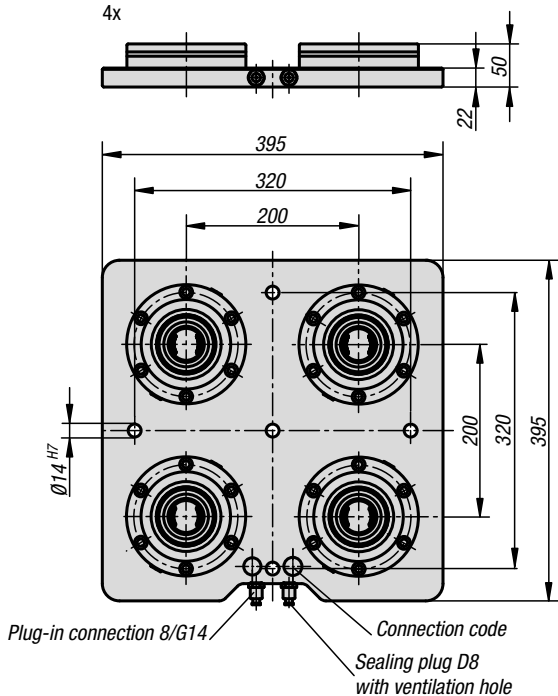

**Material:**

Clamping module mild steel.  
Base plate steel 1.1730.

**Version:**

Clamping module contact surfaces case-hardened and ground.  
Base plate ground on both sides.

**Sample order:**

K1009.4200395395

**Note:**

Completely mounted multi-clamping stations with integrated UNI lock Ø138 mm mounting clamps. The clamping stations are secured to the machine table directly or with clamps.

Common bore patterns are pre-centred on the rear side for mounting.

Clamping stations can be aligned via the 14H7 reference holes.

The clamping stations are actuated via a central pneumatic connection.

The high clamping forces are generated by the integrated spring package (the unit clamps in the de-pressurized state).

The release process occurs pneumatically.

The following retaining forces are possible with the UNI lock clamping bolt in conjunction with mounting screws M10, M12, M16.

- Retaining force (M10) 35,000N/module
- Retaining force (M12) 50,000N/module
- Retaining force (M16) 75,000N/module

**On request:**

Clamping station in special dimensions.

**Technical data:**

- Opening pressure: 6bar, lubricated air
- Turbo pressure: 6bar
- Air connection: G1/4
- Repeat accuracy ≤ 0.005 mm
- Reference holes 14H7 to align the clamping plate.
- Pneumatic connectors for 6 mm pneumatic hose.

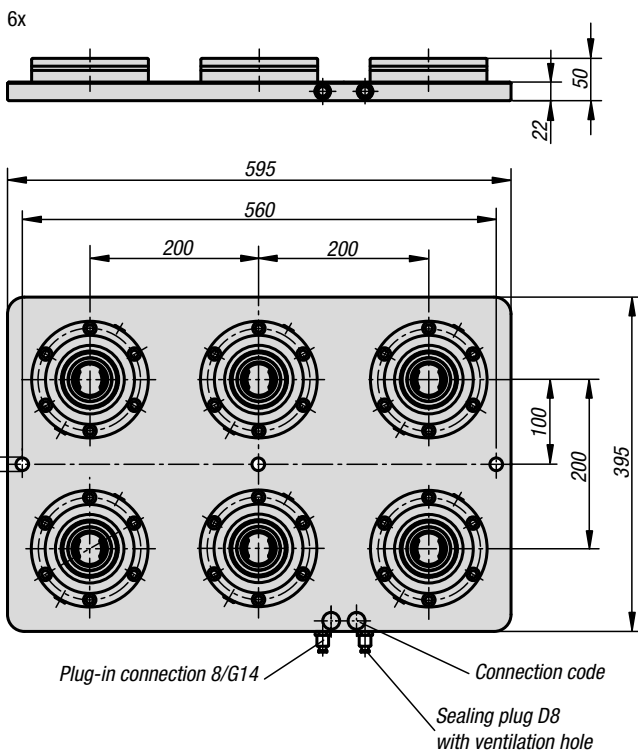

## KIPP UNI lock clamping station

Order No.	Type	weight kg
K1009.4200395395	4x	58
K1009.6200595395	6x	52.2

## UNI lock installation clamp



Without rotation lock

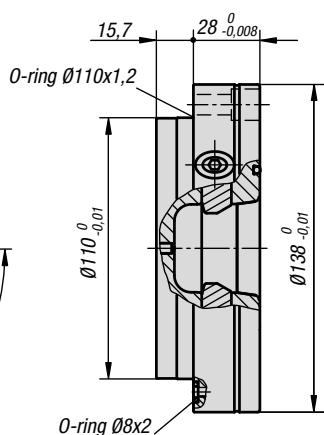
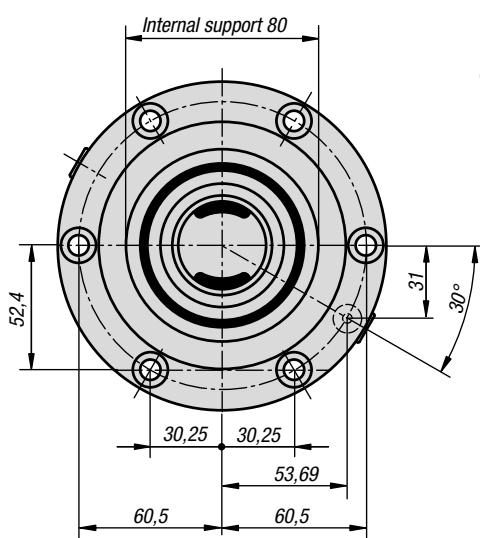

With rotation lock

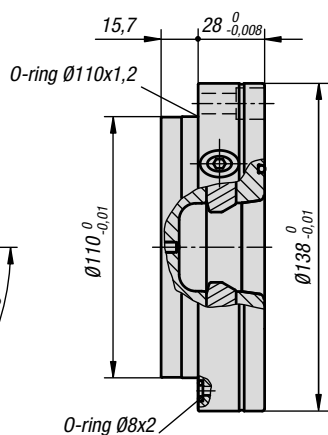
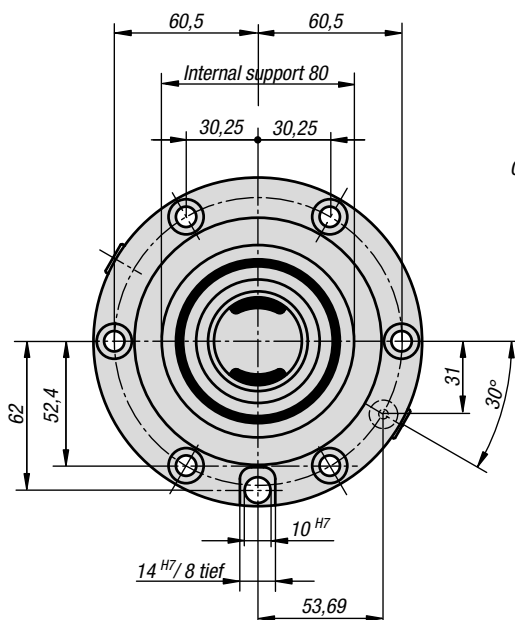

**Material:**  
Steel.

**Version:**  
Contact faces case-hardened and ground.

**Sample order:**  
K1003.138280

**Note:**  
The UNI lock mounting clamps can be installed in any position on machine tables, fixtures or workholding equipment (tooling plates, cubes, tombstones etc). The modular design enables the number of clamps and distance between them to be ideally adjusted to suit the clamping task. The clamps can be supplied with or without rotation lock.

The high clamping forces are generated by the integrated spring package (the unit clamps when depressurised). Compressed air is applied to release the clamp.

The following holding forces are possible with the UNI lock clamping bolt in conjunction with M10, M12 or M16 fastening screws:

- Holding force (M10) 35,000N
- Holding force (M12) 50,000N
- Holding force (M16) 75,000N

**Supplied with:**  
1x clamping module incl. 6 fastening screws.  
6x screw protection caps.  
2x air connection O-rings.  
1x installation O-ring.

**Technical data:**  
- Opening pressure: 6 bar, lubricated air  
- Turbo pressure: 6 bar  
- Air connection: G 1/8"  
- Repeat accuracy  $\leq 0.005$  mm

### KIPP UNI lock installation clamp

Order No.	Version	weight kg
K1003.138280	Without rotation lock	3.56
K1003.138281	With rotation lock	3.52

## UNI lock installation clamp



**Material:**  
Steel.

**Version:**  
Contact faces case-hardened and ground.

**Sample order:**  
K1385.138390

**Note:**  
The UNI lock mounting clamps can be installed in any position on machine tables, fixtures or workholding equipment (tooling plates, cubes, tombstones etc). The modular design enables the number of clamps and distance between them to be ideally adjusted to suit the clamping task. The high clamping forces are generated by the integrated spring package (the unit clamps when depressurised). Compressed air is applied to release the clamp.

The following holding forces are possible with the UNI lock clamping bolt in conjunction with M10, M12 or M16 fastening screws:

- Holding force (M10) 35,000N
- Holding force (M12) 50,000N
- Holding force (M16) 75,000N

Supplied with:  
1x clamping module incl. 6 fastening screws.  
6x screw protection caps.  
2x air connection O-rings.  
1x installation O-ring.

**Technical data:**

- Opening pressure: 6 bar, lubricated air
- Turbo pressure: 6 bar
- Air connection: G 1/8"
- Repeat accuracy  $\leq 0.005$  mm

**Drawing reference:**  
1) O-ring ( $\varnothing 8 \times 2$ )  
2) O-ring ( $\varnothing 110 \times 1,2$ )

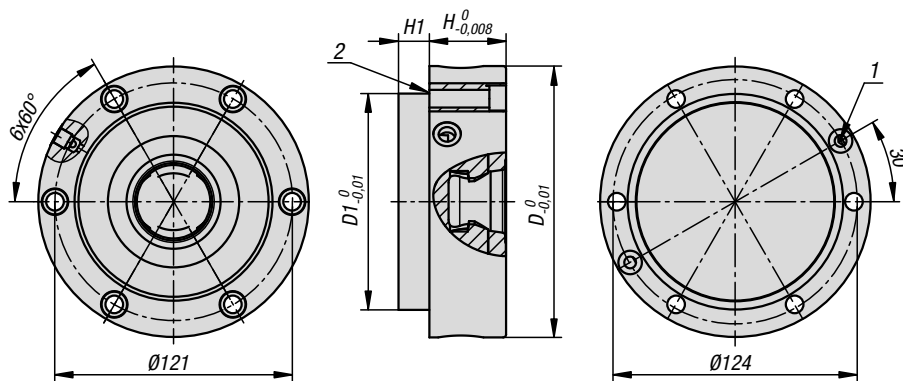

## KIPP UNI lock installation clamp

Order No.	Version	D	D1	H	H1
K1385.138390	without rotation lock	138	110	39	15,7

## UNI lock mounting clamps



**Material:**  
Steel.

**Version:**  
Contact faces case-hardened and ground.

**Sample order:**  
K1389.176390

**Note:**  
The UNI lock mounting clamps can be installed in any position on machine tables, fixtures or workholding equipment (tooling plates, cubes, tombstones etc).  
The modular design enables the number of clamps and distance between them to be ideally adjusted to suit the clamping task. The clamps can be supplied with or without rotation lock. The high clamping forces are generated by the integrated spring package (the unit clamps when depressurised). Compressed air is applied to release the clamp.

The following holding forces are possible with the UNI lock clamping bolt in conjunction with M10, M12 or M16 fastening screws:

- Holding force (M10) 35,000N
- Holding force (M12) 50,000N
- Holding force (M16) 75,000N

Supplied with:  
1x clamping module incl. 6 fastening screws.  
6x screw protection caps.  
2x air connection O-rings.  
1x installation O-ring.

**Technical data:**

- Opening pressure: 6 bar, lubricated air
- Turbo pressure: 6 bar
- Air connection: G 1/8"
- Repeat accuracy  $\leq 0.005$  mm

**Drawing reference:**  
1) O-ring ( $\varnothing 8 \times 2$ )  
2) O-ring ( $\varnothing 138$ )

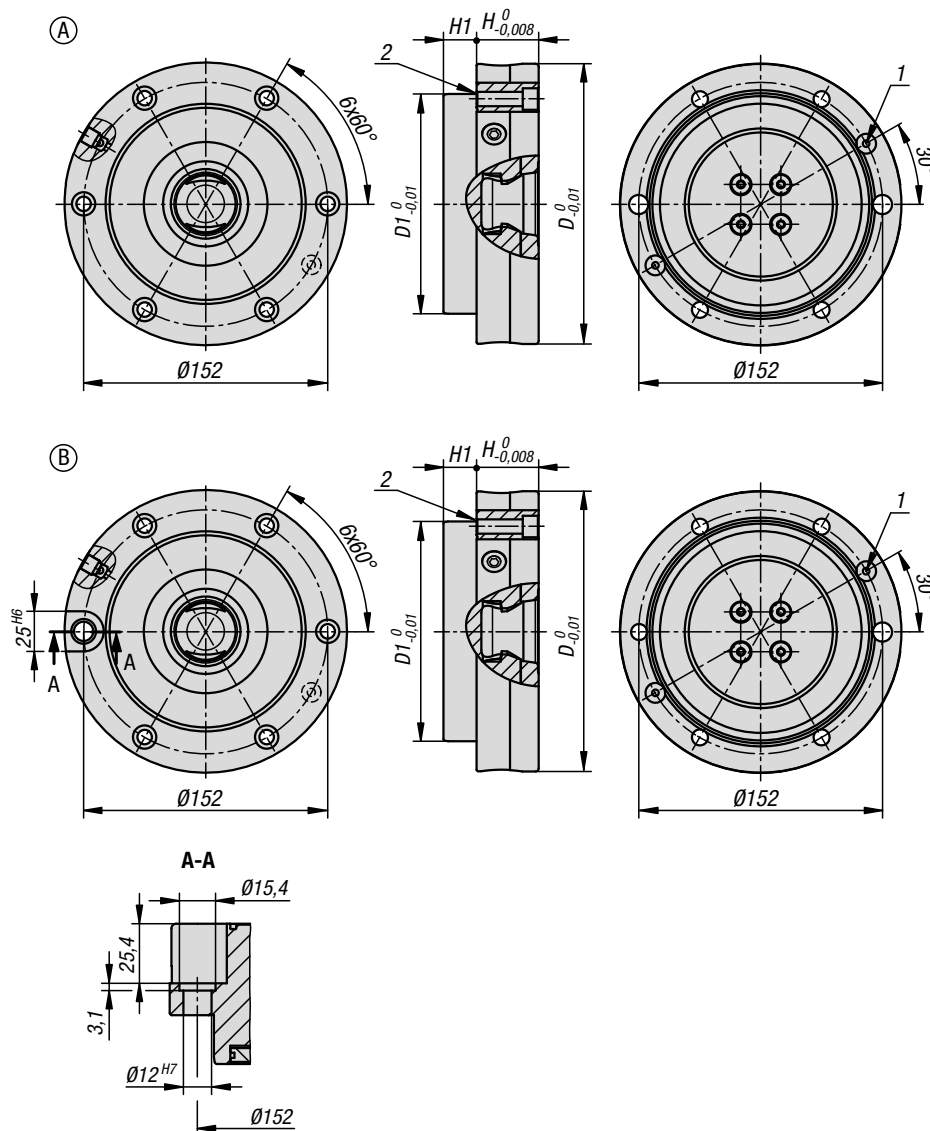

### KIPP UNI lock mounting clamps

Order No.	Form	Version	D	D1	H	H1
K1389.176390	A	without rotation lock	176	138	39	20,8
K1389.176391	B	with rotation lock	176	138	39	20,8



# UNI lock double clamping module



**Material:**  
Steel.

**Version:**  
Contact faces case-hardened and ground.

**Sample order:**  
K1122.1381500

**Note:**  
UNI lock double clamp modules are particularly suitable for the direct clamping of workpieces. Workpieces with complex geometry can be completely machined on 4 and 5 sides. UNI lock double clamp modules can be mounted in any position.

The high clamping forces are generated by the integrated spring package. (the unit clamps while not pressurised). Clamping is released pneumatically. The following clamping forces are possible with the UNI lock clamping pin in conjunction with M10, M12, M16 fastening screws:  
Clamping force (M10) 35,000 N  
Clamping force (M12) 50,000 N  
Clamping force (M16) 75,000 N

Supplied with:  
1 double clamp module incl. 3x pneumatic connections.

**Technical data:**  
Opening pressure: 6 bar, lubricated air  
Turbo pressure: 6 bar  
Air connection: G 1/8  
Repeat accuracy  $\leq 0.005$  mm

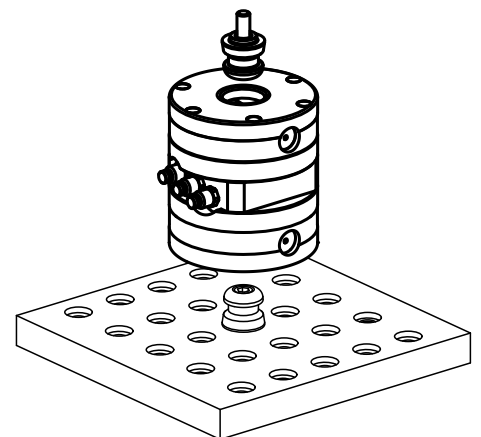
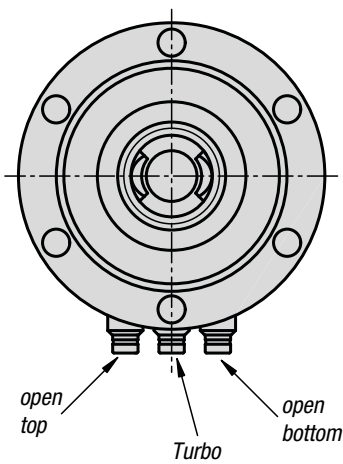
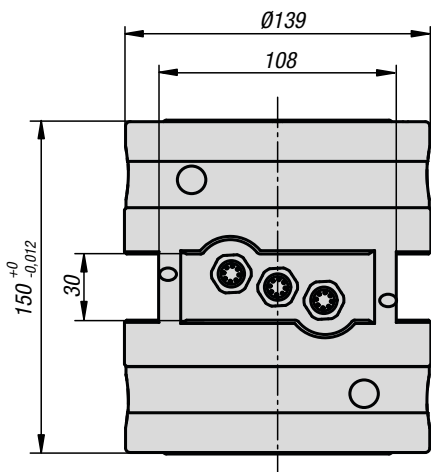

## KIPP UNI lock double clamping module

Order No.	Type	weight kg
K1122.1381500	double clamp	3

# UNI lock manual clamping module



**Material:**  
Steel.

**Version:**  
Contact faces case-hardened and ground.

**Sample order:**  
K1123.1605050

**Note:**  
UNI lock manual clamping modules can be adapted directly to machine tables with grid holes or T-slots, and to grid hole subplates with 50 mm grid spacing system size M10/M12/M16.  
The UNI lock manual clamping module H 50 is particularly suitable for machines with reduced Z travel. The low installation height of the manual clamping module facilitates full utilisation of the Z travel.  
The UNI lock manual clamping module H 50 can be mounted in any position.

Supplied with:  
1 manual clamping module incl. fastening accessories.

**Technical data:**  
Repeat accuracy  $\leq 0.005$  mm

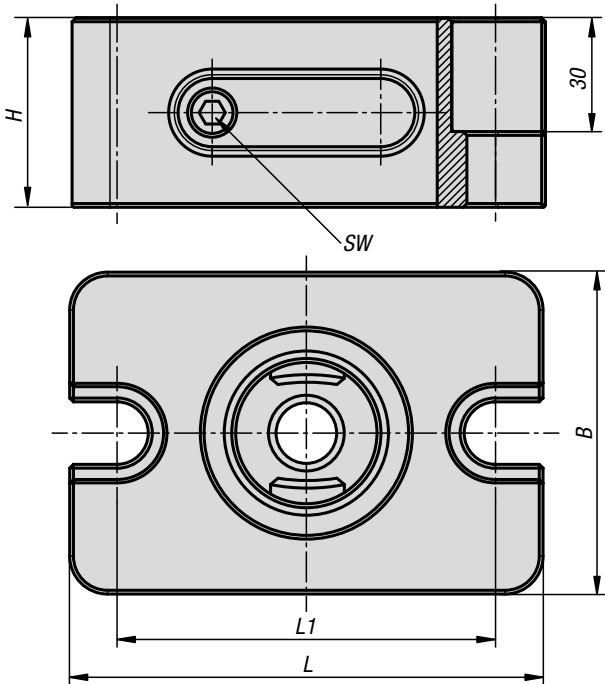

**Mounting accessories**

M12:

M16:

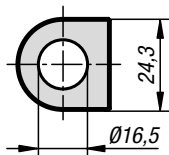
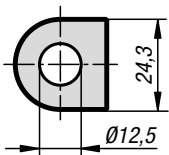

**KIPP UNI lock manual clamping module**

Order No.	B	H	L	L1	SW	weight kg
K1123.1605050	85	50	125	100	6	3.52

## Interchangeable subplates

for UNI lock zero-point clamping system

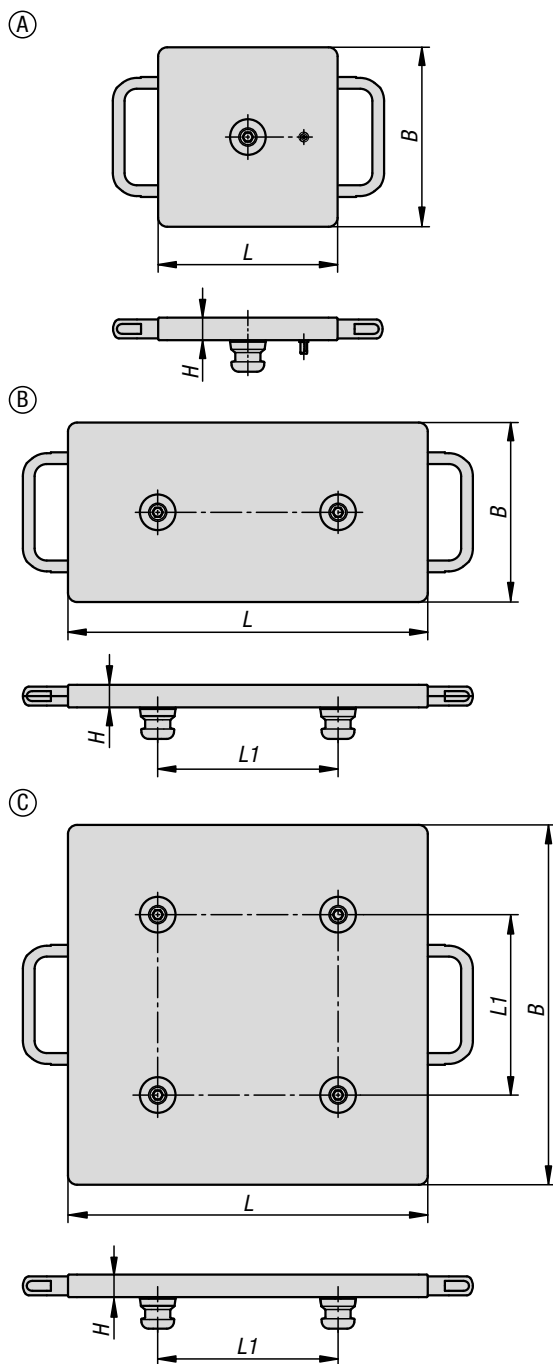

**Material:**  
High-strength aluminium.

**Sample order:**  
K1218.1000200200

**Note:**  
Interchangeable subplates are particularly suitable for quickly exchanging fixtures on zero point clamping plates. Ground on both sides, standard clamping pin gauge of 200 mm. Complete with clamping pins and handles.

**On request:**  
Further gauges and special sizes.

### KIPP Interchangeable subplates for UNI lock zero point clamping system

Order No.	Form	B	H	L	L1	weight ca. kg
K1218.1000200200	A	199	25	199	-	1
K1218.2200200200	B	199	25	399	200	6.02
K1218.4200400400	C	399	25	399	200	11.88

# UNI lock clamping pin

size 80 mm



**Material:**  
Steel.

**Version:**  
Hardened and black oxidised.  
Contact faces ground.

**Sample order:**  
K0967.140160512

**Note:**  
The UNI lock clamping pin is suitable for clamping and positioning workpieces and fixtures. Clamping pins are screwed onto the exchange element and adapted to the various basic modules.

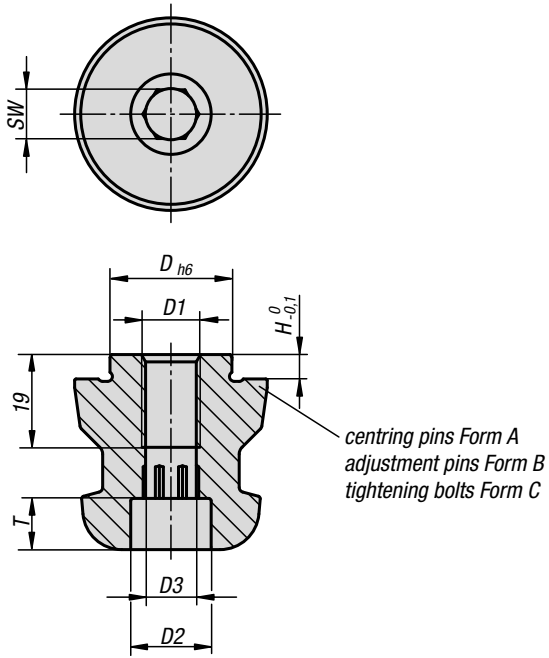

- Centring pins = Form A      fixes in x and y axis (reference point)
- Adjustment pins = Form B      fixes the free axis (bayonet pin)
- Tightening bolts = Form C      Pins with undersize (no centring function, clamping only)

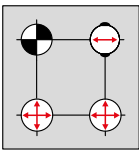

- 1 = fastening with grub screw DIN 913
- 2 = fastening with DIN 912 screw through the tightening bolt
- 3 = fastening with DIN 912 screw through the fixture or workpiece

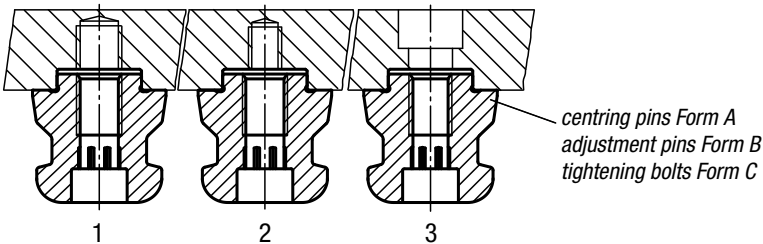

## UNI lock clamping pin

size 80 mm



## KIPP UNI lock clamping pin

Order No.	Form	D	D1	D2	D3	H	T	SW
K0967.140160512	A	16	M12	16,5	10,3	5	10,5	10
K0967.140180512	A	18	M12	16,5	10,3	5	10,5	10
K0967.140200512	A	20	M12	16,5	10,3	5	10,5	10
K0967.140220516	A	22	M16	18,5	14,2	5	12,5	17
K0967.140240516	A	24	M16	18,5	14,2	5	12,5	17
K0967.140250512	A	25	M12	16,5	10,3	5	10,5	10
K0967.140250516	A	25	M16	18,5	14,2	5	12,5	17
K0967.140251012	A	25	M12	16,5	10,3	10	10,5	10
K0967.140251016	A	25	M16	18,5	14,2	10	12,5	17
K0967.240160512	B	16	M12	16,5	10,3	5	10,5	10
K0967.240180512	B	18	M12	16,5	10,3	5	10,5	10
K0967.240200512	B	20	M12	16,5	10,3	5	10,5	10
K0967.240220516	B	22	M16	18,5	14,2	5	12,5	17
K0967.240240516	B	24	M16	18,5	14,2	5	12,5	17
K0967.240250512	B	25	M12	16,5	10,3	5	10,5	10
K0967.240250516	B	25	M16	18,5	14,2	5	12,5	17
K0967.240251012	B	25	M12	16,5	10,3	10	10,5	10
K0967.240251016	B	25	M16	18,5	14,2	10	12,5	17
K0967.340160512	C	16	M12	16,5	10,3	5	10,5	10
K0967.340180512	C	18	M12	16,5	10,3	5	10,5	10
K0967.340200512	C	20	M12	16,5	10,3	5	10,5	10
K0967.340220516	C	22	M16	18,5	14,2	5	12,5	17
K0967.340240516	C	24	M16	18,5	14,2	5	12,5	17
K0967.340250512	C	25	M12	16,5	10,3	5	10,5	10
K0967.340250516	C	25	M16	18,5	14,2	5	12,5	17
K0967.340251012	C	25	M12	16,5	10,3	10	10,5	10
K0967.340251016	C	25	M16	18,5	14,2	10	12,5	17

# K1010

## Protective bolt

for clamping module

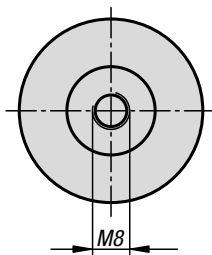
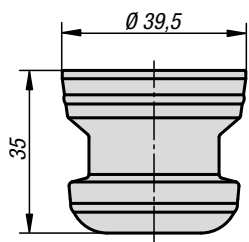

**Material:**  
Aluminium.

**Version:**  
Black anodized

**Sample order:**  
K1010.040

**Note:**  
Protection bolt to cover the hole.

### KIPP Protective bolts for clamping module

Order No.	Dimensions
K1010.040	see drawing

# K1010

## Protective plug

for clamping module

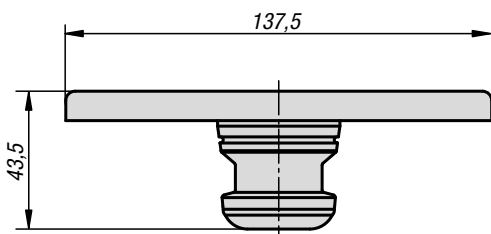

**Material:**  
Aluminium.

**Version:**  
Black anodized

**Sample order:**  
K1010.138

**Note:**  
Protective plug for clamping module D = 138.

### KIPP Protective plug for clamping module

Order No.	Dimensions
K1010.138	see drawing

## Quick-fit couplings

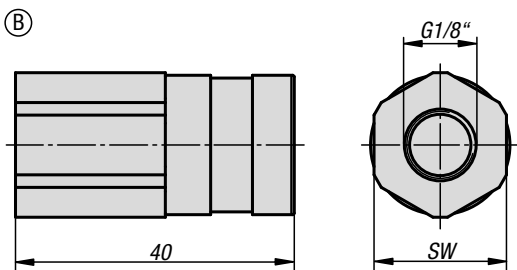
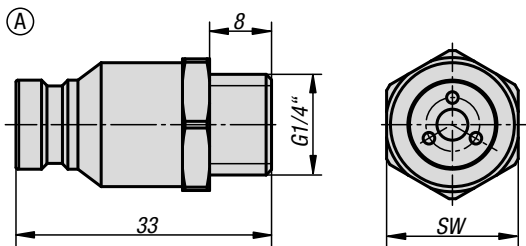

**Material:**  
Steel.

**Version:**  
galvanized.

**Sample order:**  
K1011.0014

**Note:**  
Quick-fit couplings suitable for UNI lock clamping stations.

### KIPP Quick-fit couplings

Order No.	Form	SW
K1011.0014	A	17
K1011.1018	B	19

## Notes

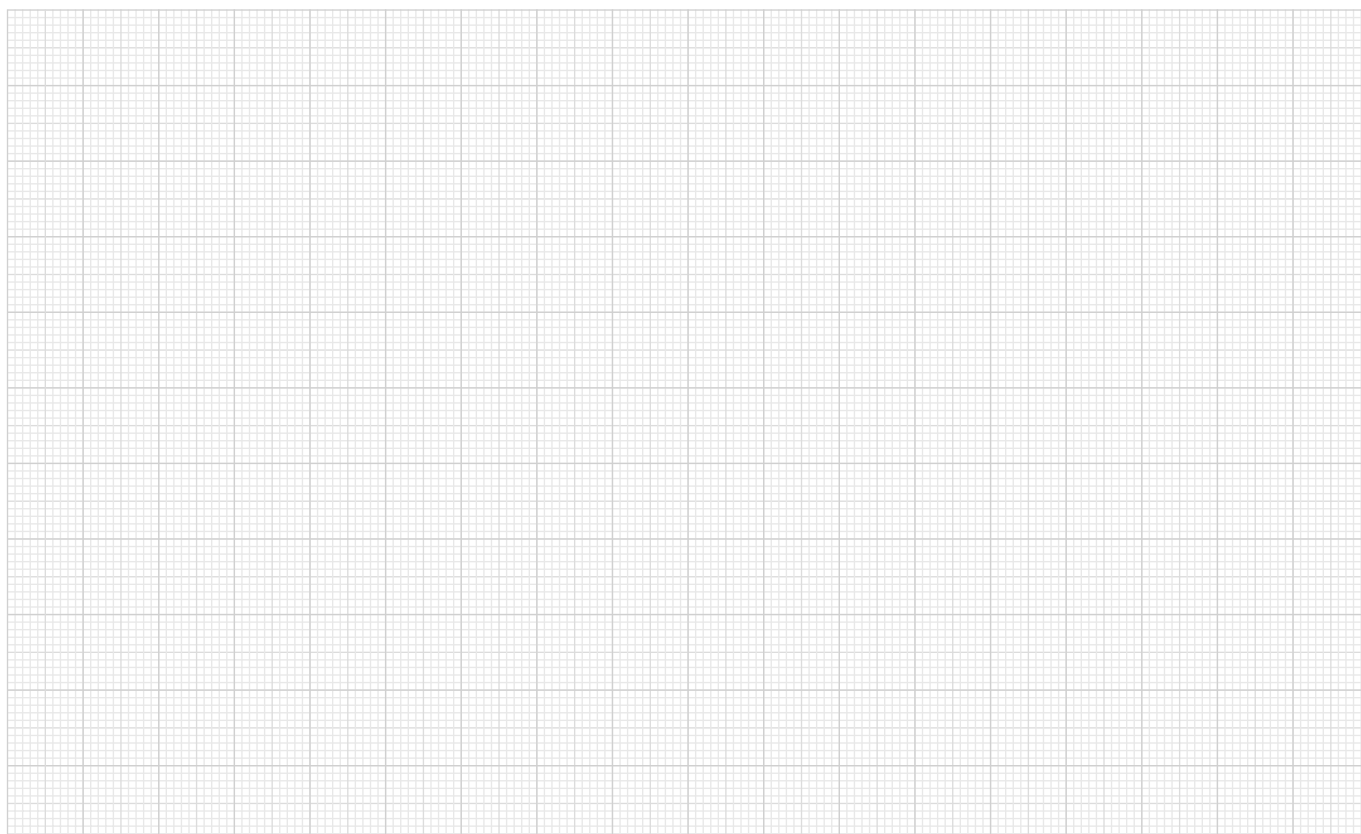

# Example

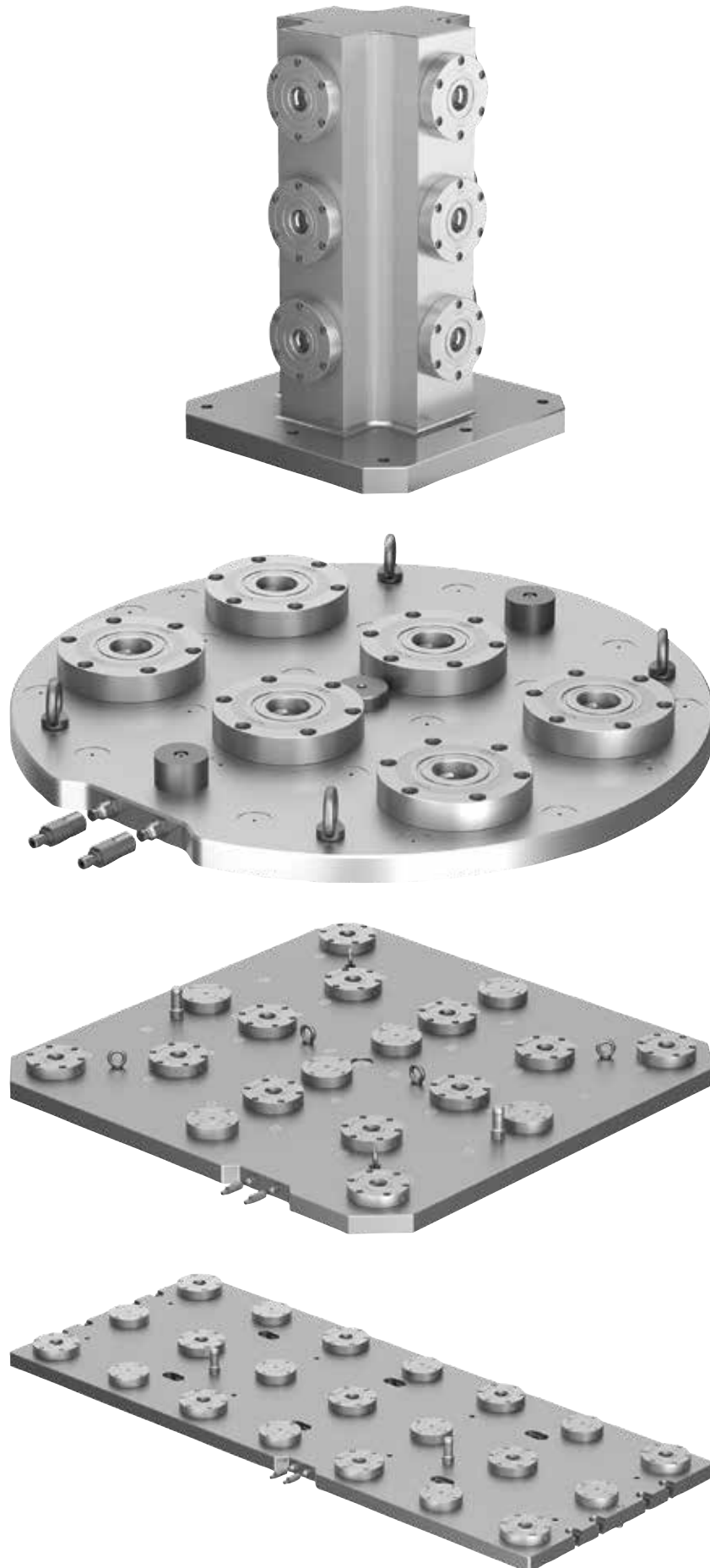



Example





## 5-axis module clamping system 80



# Function



UNI lock was developed specifically for 5-side machining. Ideal for clamping complex workpiece's. They can then be machined completely in a single clamping operation. Even machining from the 6th side is possible. The workpiece's are connected to the 5-axis module system by a screw connection.

System size 80 mm



## ADVANTAGES:

- 5-side machining with no protruding edges
- Modular construction guarantees maximum flexibility
- Interfaces with commonly used systems
- Variable workpiece fastening
- The workpiece is positively joined to the clamping system
- The workpiece is simply positioned with screws or seating's
- The zero point is transferred to the workpiece
- High module clamping force
- Very high repeat accuracy

Thanks to the modular construction and the variety of modules, the system can be configured individually and recombined for many applications.

More than 70 elements are available: basic modules, add-on modules and accessories.  
In combination, they guarantee a variety of heights, docking to interfaces and machining  
of complex workpiece's.

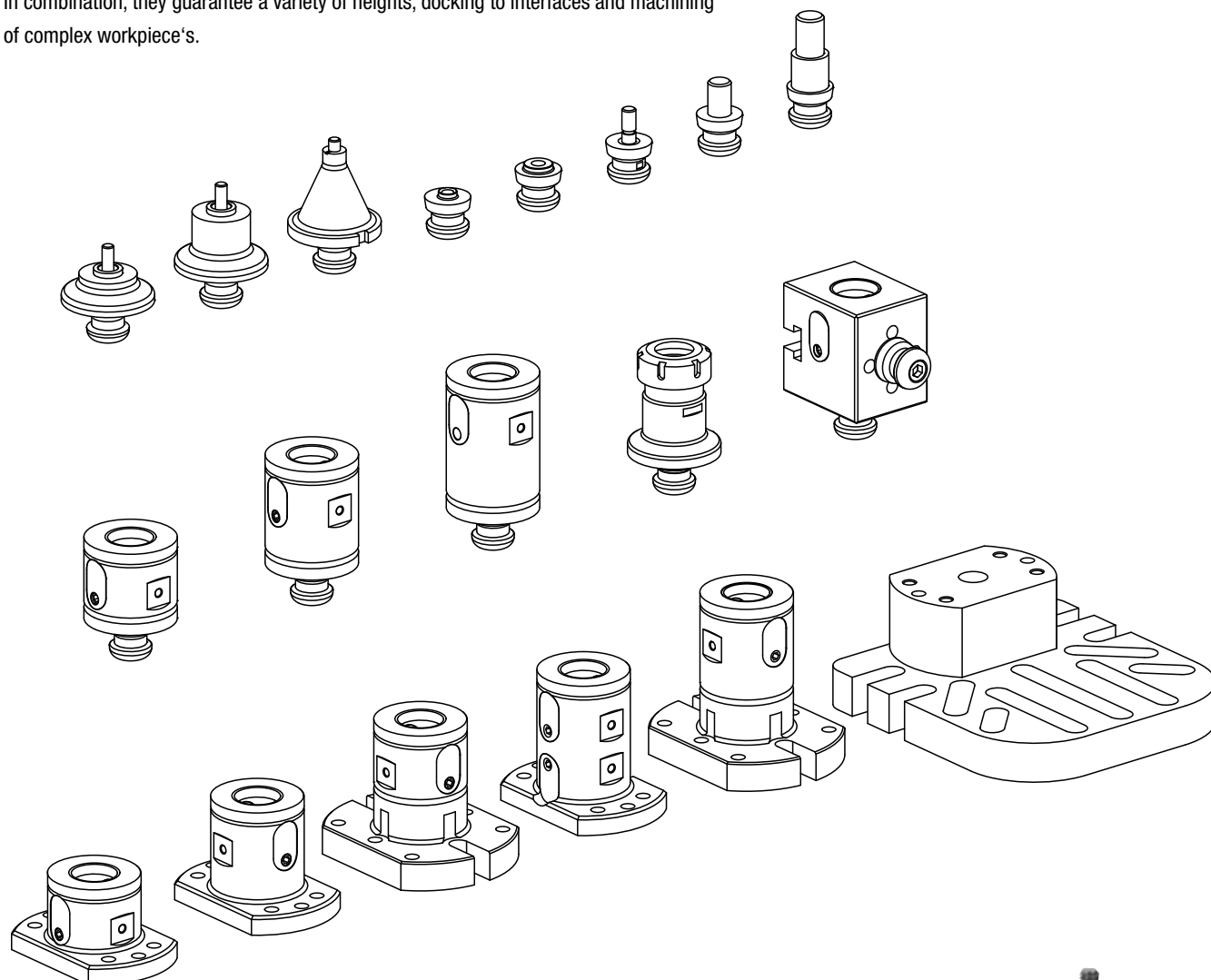

Flexible stack heights through a wide variety of basic and add-on clamp modules

# Setup times



## Without KIPP UNI lock:

Conventional machining of the workpiece in a vice: It is necessary to reclamp the workpiece several times to complete machining.

Disadvantage: Enormous time loss due to repeat workpiece setups.  
Accuracy is lost through repeated setups.

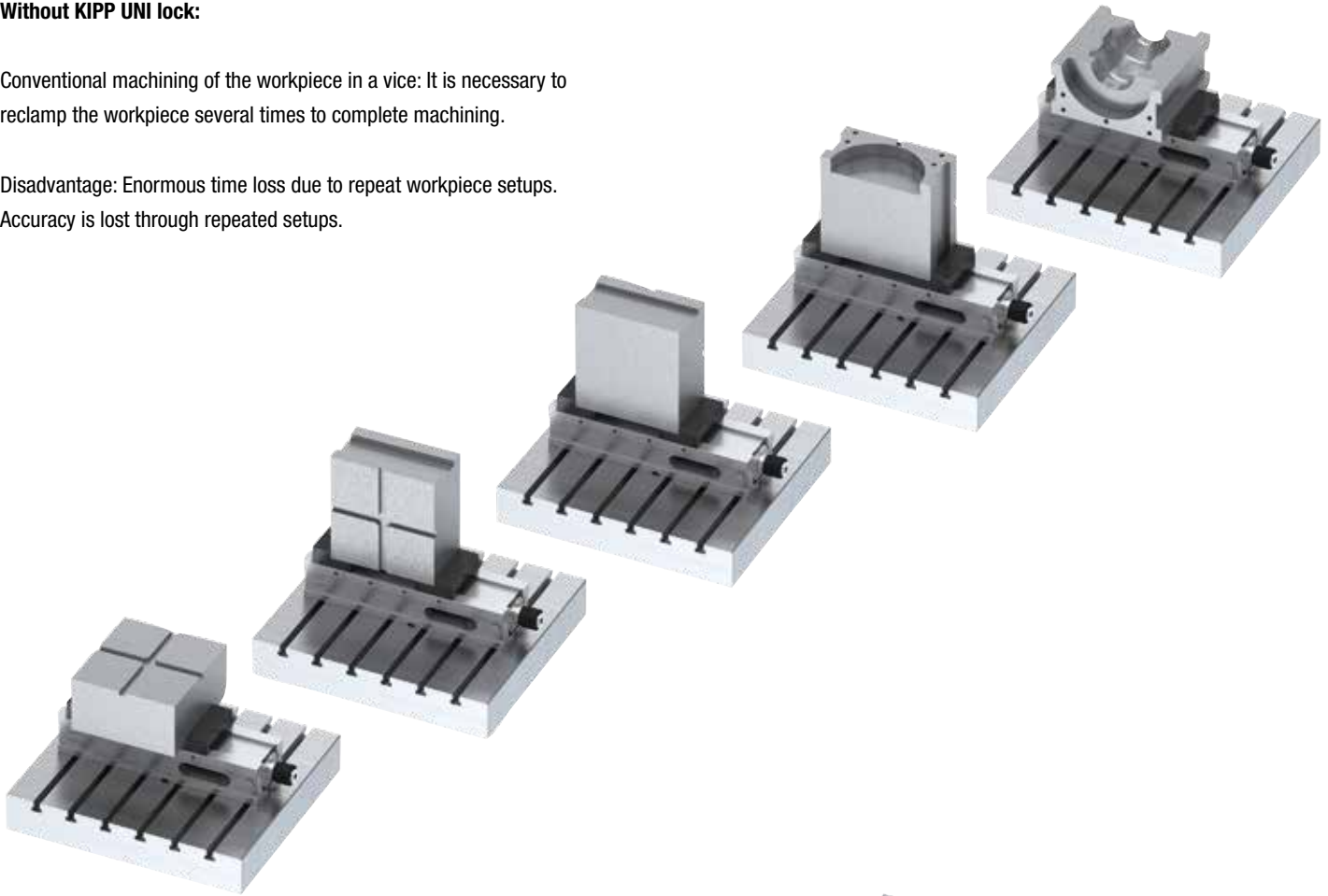

## With KIPP UNI lock:

Machining with the UNI lock 5-axis module system:  
The workpiece is machined completely in 2 clamping operations.

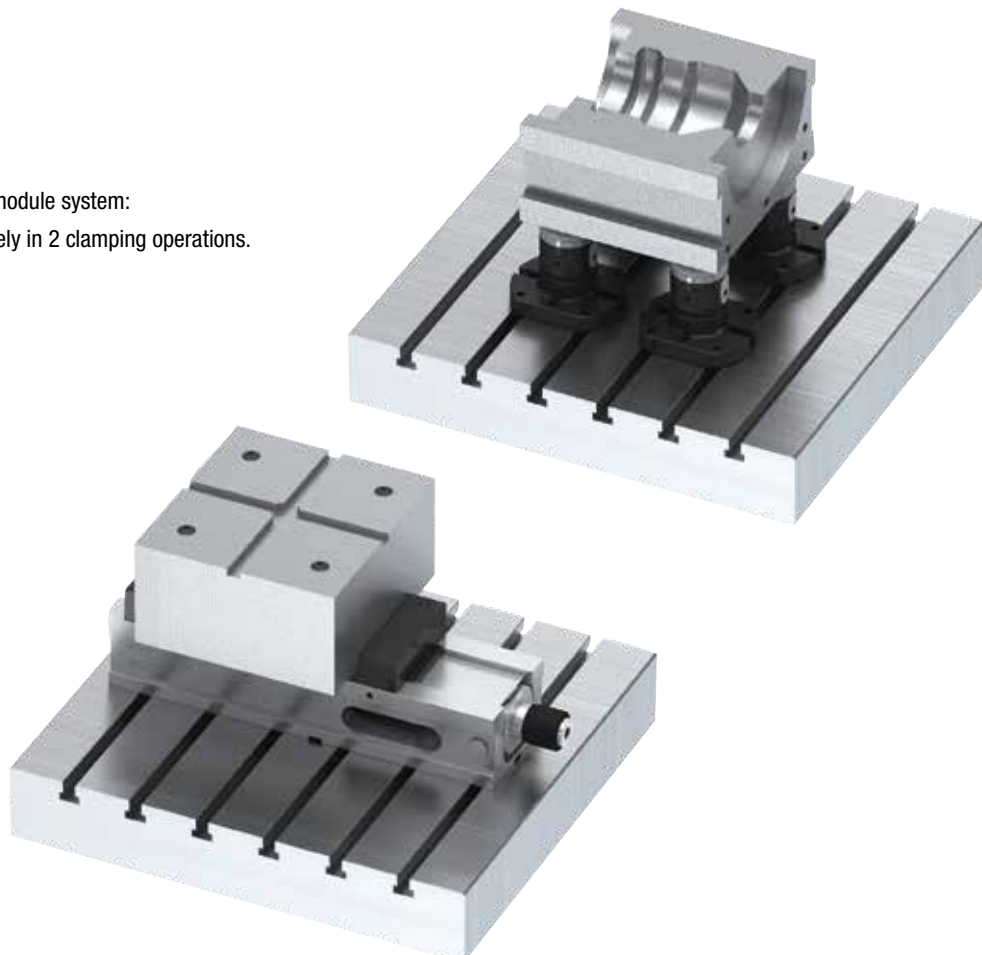

# Interfaces



The 5-axis module system can be mounted on T slot tables, grid systems or directly to machine tables. Moreover, the basic modules can be adapted to most common zero-point clamping systems.

---

**T-slot tables**



---

**Grid systems**



---

**Machine tables**



---

**Zero-point clamping systems**



# Forces

system size 80 mm



- Fr**    Permissible transverse force
- Fa**    Permissible clamping force
- Fd**    Permissible contact force
- Fe**    Clamping bolt pull-in force

**Permissible load with full contact:**

		Fr	Fa	Fd	Fe
Clamping pin screw M10	kN	25	35	50	25
Clamping pin screw M12	kN	25	50	50	25
Clamping pin screw M16	kN	25	75	50	25



Max. tightening torque 15 Nm (system size 80 mm)



# Example



The workpiece is secured on one, two or more stable module columns. Additional columns can be added easily for large parts. The clamping system is actuated manually without the need for power sources and can be converted very quickly for other workpiece's or fixtures.

Assembling the modules is remarkably simple: position basic module (bolt on from above or below), place add-on clamp modules, position reducer adaptors with bolted-on workpiece and then use a torque wrench to tighten manually. The system is now stable and ready for 5-axis machining.



4 basic modules H=100 positioned directly on the machine table. The 4 reducers H=50 on top facilitate optimum access to workpieces.

**Clamping height 150 mm**

# Example



KIPP basic module with collet adaptor mounted directly on a machine table with T-slots.

**Clamping height 220 mm**



Gearbox housing mounted on 3 basic modules, 3 add-on modules and 3 reducer adaptors. The cast housing is secured to the reducer adaptors by means of socket-head screws.

**Clamping height 250 mm**



4 double clamp basic modules positioned on a tooling plate. Optimum 5-side machining is possible.

**Clamping height 125 mm**



Solid workpiece mounted on 4 basic modules and 4 add-on modules.

**Clamping height 150 mm**



2 basic modules with a centring clamp adapted directly to a zero-point clamping system.

**Clamping height 125 mm**



Loading procedure for mounting a long and heavy workpiece on 3 basic modules. Clamp spigots are mounted directly on the workpiece. The workpiece is positioned during clamping.

**Clamping height 100 mm**



## UNI lock 5-axis basic module

system size 80 mm

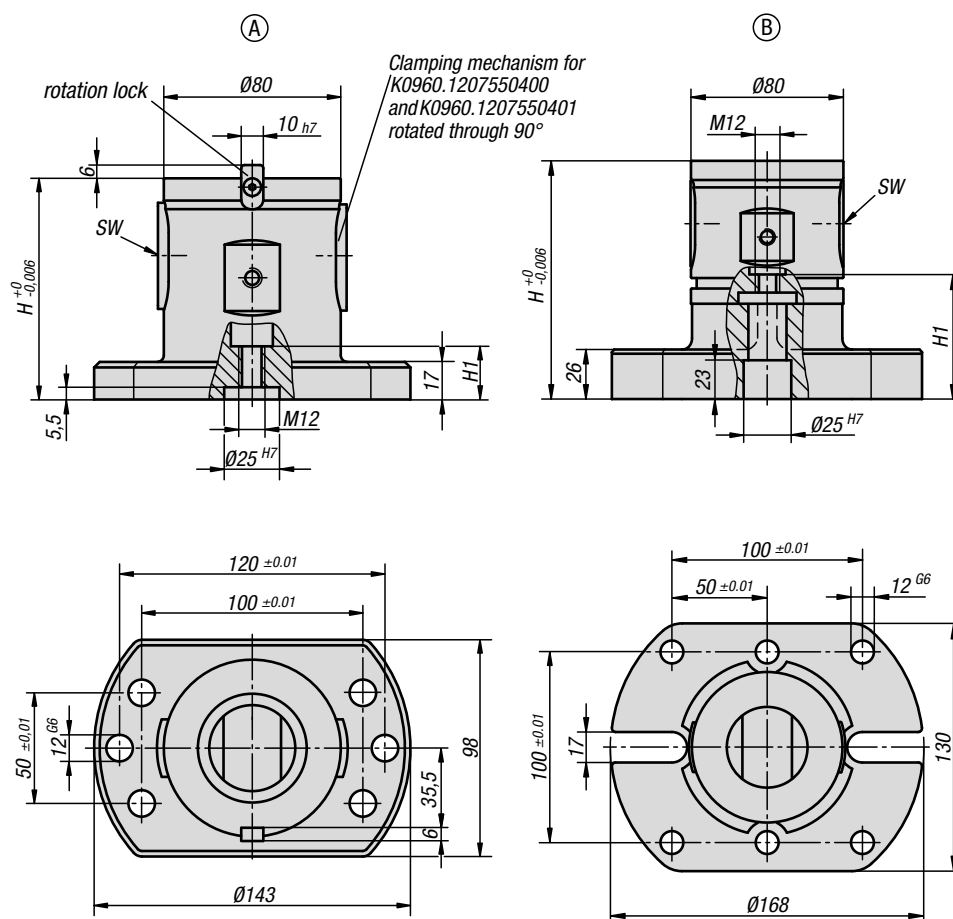

**Material:**  
Steel.

**Version:**  
Main body oxidised.  
Contact faces case-hardened and ground.

**Sample order:**  
K0960.1207550400

**Note:**  
The UNI lock 5-axis basic module can be adapted directly to subplates with grid holes or T-slots or to tooling plates with hole pitch of 40/50 mm system size M12. Suitable for UNI lock zero point clamping system with UNI lock clamping bolts. Can also be used on the conventional zero point clamping systems by mounting an appropriate adapter clamping bolt.

### KIPP UNI lock 5-axis basic module

Order No.	Form	Version	H	H1	SW	Holding force F kN	Tightening torque max. Nm	weight kg
K0960.1207550400	A	without rotation lock	75	18,5	6	50	15	3.64
K0960.1207550401	A	with rotation lock	75	18,5	6	50	15	3.65
K0960.1210050400	A	without rotation lock	100	24	6	50	15	4.59
K0960.1210050401	A	with rotation lock	100	24	6	50	15	4.601
K0960.12125500	B	without rotation lock	125	68,5	6	50	15	6.8
K0960.12150500	B	without rotation lock	150	74	6	50	15	7.8

## UNI lock 5-axis basic module double clamp

size 80 mm



**Material:**

Steel.

**Version:**

Main body oxidised.

Contact faces case-hardened and ground.

**Sample order:**

K0961.1212550400

**Note:**

The UNI lock 5-axis basic module can be adapted directly to subplates with grid holes or T-slots or to tooling plates with hole pitch of 40/50 mm system size M12. Suitable for UNI lock zero point clamping system with UNI lock clamping bolts. Can also be used on the conventional zero point clamping systems by mounting an appropriate adapter clamping bolt.

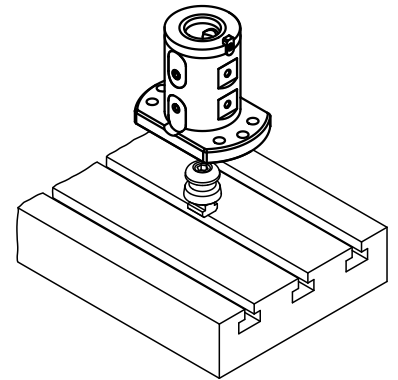
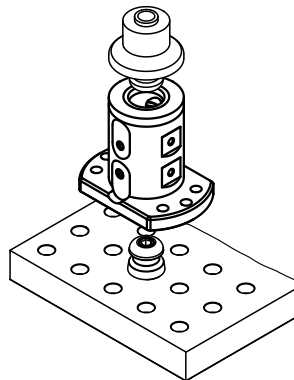
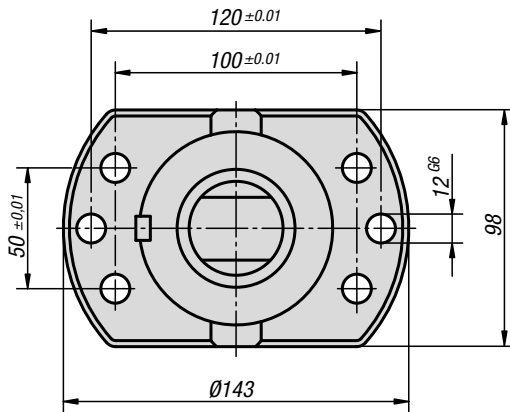
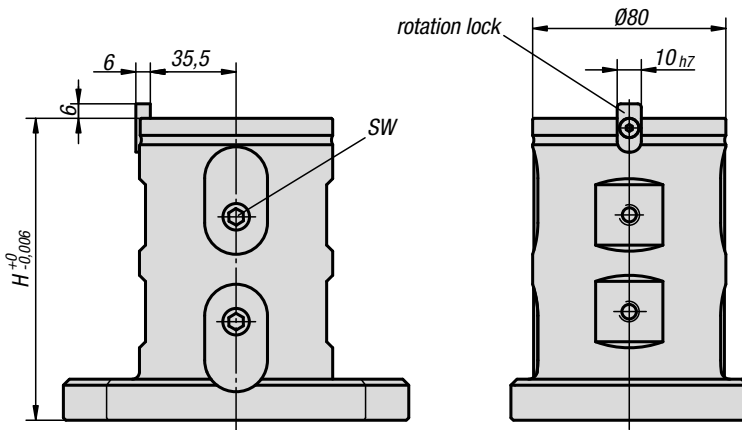

### KIPP UNI lock 5-axis basic module double clamp

Order No.	Version	H	SW	Holding force F kN	Tightening torque max. Nm	weight kg
K0961.1212550400	without rotation lock	125	6	50	15	4.96
K0961.1212550401	with rotation lock	125	6	50	15	5.2

## UNI lock 5-axis base plate

for general clamping, system size 80 mm

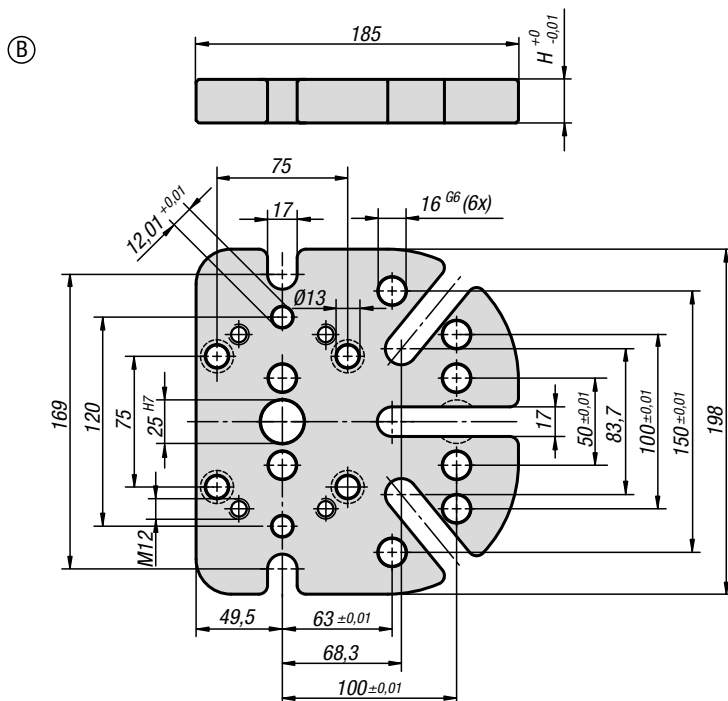
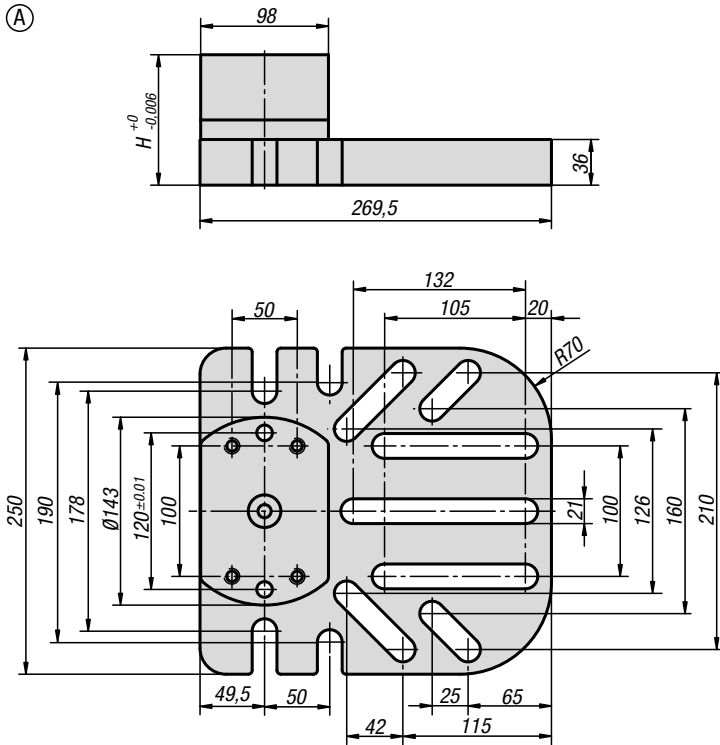

**Material:**

Steel.

**Version:**

Main body oxidised.

Contact faces case-hardened and ground.

**Sample order:**

K0962.25027005021

**Note:**

The UNI lock 5-axis base plates for general clamping are adapted directly to subplates with grid holes or T-slots or tooling plates. Due to their sturdy construction, these risers are ideal as base elements for large and heavy workpieces. The layout of the fastening keyways allows for a flexible adjustment to the workpiece.

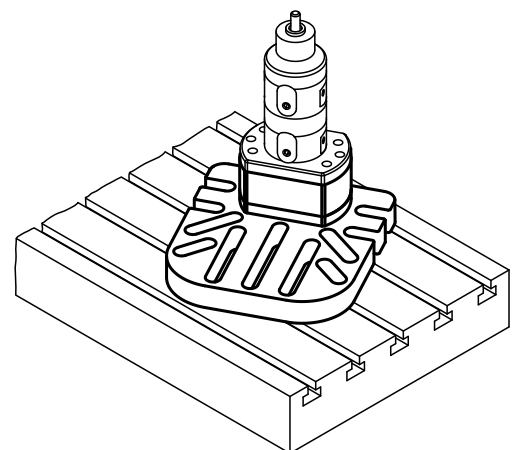

### KIPP UNI lock 5-axis base plate for general clamping

Order No.	Form	H	weight kg
K0962.25027005021	A	50	14.7
K0962.25027010021	A	100	19
K0962.25027012521	A	125	22.1
K0962.19818502516	B	25	6.5

## UNI lock 5-axis add-on clamping module

size 80 mm

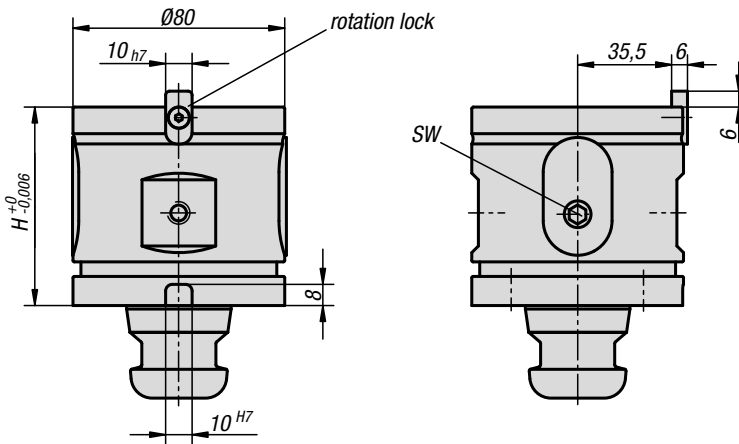

**Material:**

Steel.

**Version:**

Main body oxidised.

Contact faces case-hardened and ground.

**Sample order:**

K0963.120750

**Note:**

The UNI lock 5-axis add-on modules are used for raising basic modules and mounting base. Depending on the clamping situation, optimum assembly height can be achieved using a combination of the basic module and add-on module.

### KIPP UNI lock 5-axis add-on clamping module

Order No.	Version	H	SW	Holding force F kN	Tightening torque max. Nm	weight kg
K0963.120750	without rotation lock	75	6	50	15	2.64
K0963.120751	with rotation lock	75	6	50	15	2.85
K0963.121000	without rotation lock	100	6	50	15	3.78
K0963.121250	without rotation lock	125	6	50	15	4.625

## UNI lock 5-axis collet adapter

size 80 mm

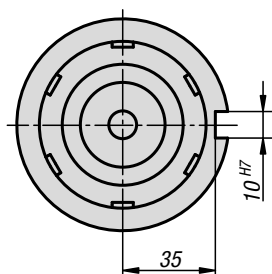
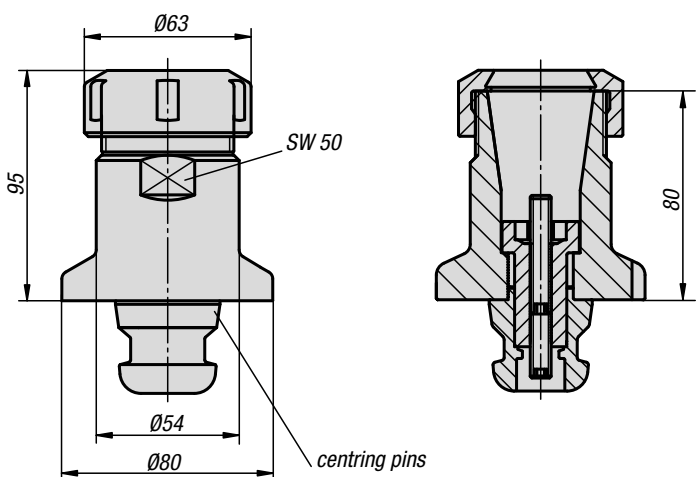

**Material:**  
Steel.

**Version:**  
Main body oxidised.  
Contact faces case-hardened and ground.

**Sample order:**  
K0964.25080

**Note:**  
The UNI lock 5-axis collet adapter is suitable for clamping round workpieces. Standard collets with the ER 40 designation can be used. Clamping up to D=26 mm. Supplied with adjustable length stop but without collets. The collet adapters can be directly mounted on the basic module with rotation lock or on the add-on module H 75 mm with rotation lock.

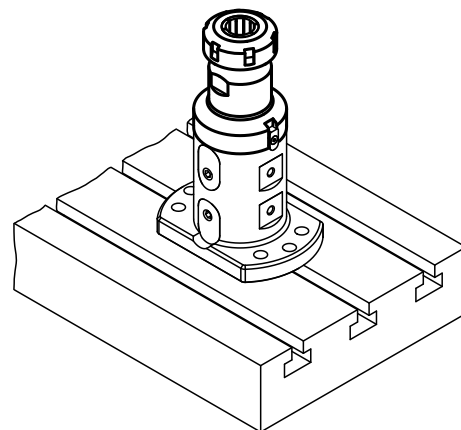

### KIPP UNI lock 5-axis collet adapter

Order No.	Dimensions
K0964.25080	see drawing



## UNI lock 5-axis face-grip adapter

size 80 mm

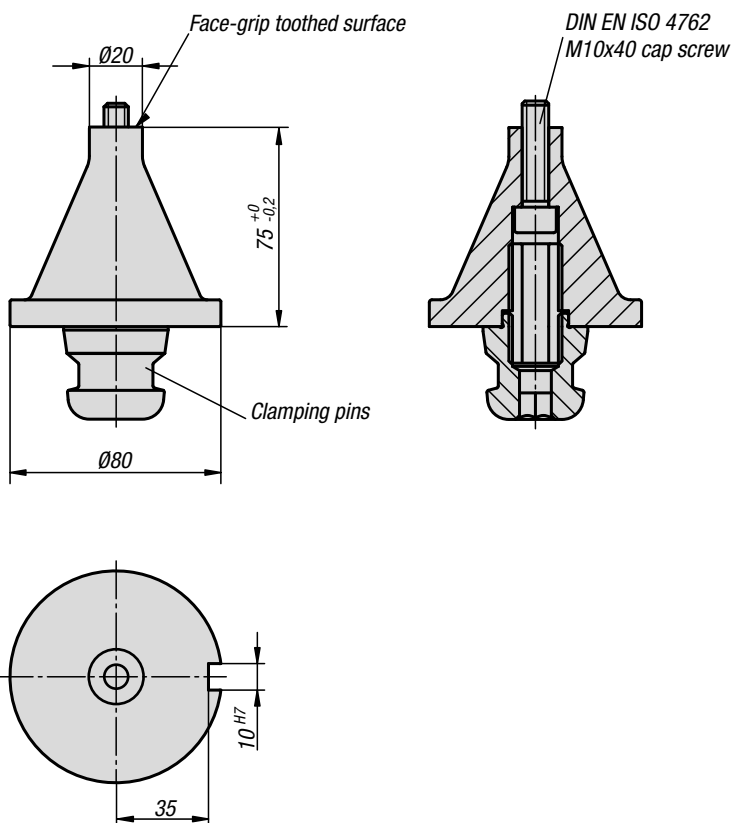
**Material:**

Steel.

**Version:**

Main body oxidised.

Contact faces case-hardened and ground.

**Sample order:**

K0965.2007510

**Note:**

The UNI lock 5-axis face-grip adapters are suitable for clamping workpieces, which must be machined on all sides. The workpieces are freely accessible without interfering edges from the clamping elements. The workpieces are attached from below using a socket head screw to pull them onto the face-grip toothed surface. The face-grip adapters can be directly mounted on the basic module with rotation lock or on the add-on module H 75 mm with rotation lock.

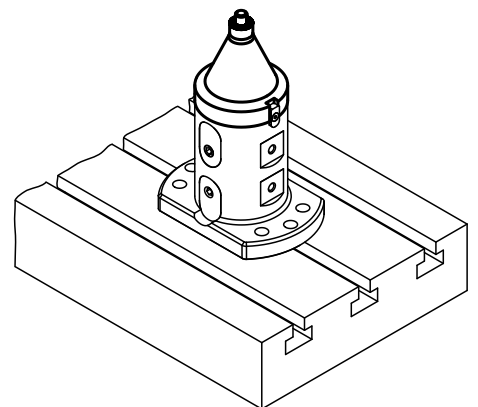

## KIPP UNI lock 5-axis face-grip adapter

Order No.

Dimensions

K0965.2007510

see drawing

## UNI lock 5-axis reducer adapter

size 80 mm

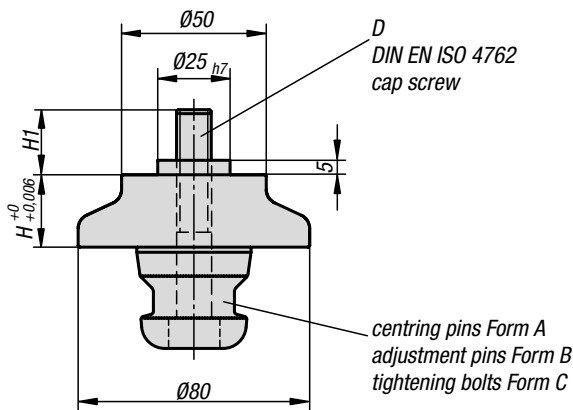

- Centring pins = Form A      fixes in x and y axis (reference point)
- Adjustment pins = Form B      fixes the free axis (bayonet pin)
- Tightening bolts = Form C      Pins with undersize (no centring function, clamping only)

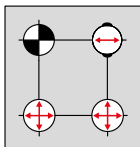

**Material:**

Steel.

**Version:**

Main body oxidised.

Contact faces case-hardened and ground.

**Sample order:**

K0966.501120

**Note:**

The UNI lock 5-axis reducer adapter is suitable for clamping and positioning workpieces. Reducer adapters can be screwed onto the workpiece and mounted on the basic module or add-on module. Reducer adapters are available as hard and soft versions. With the soft version any interfering edges on the adapter that project over the workpiece can be milled off.

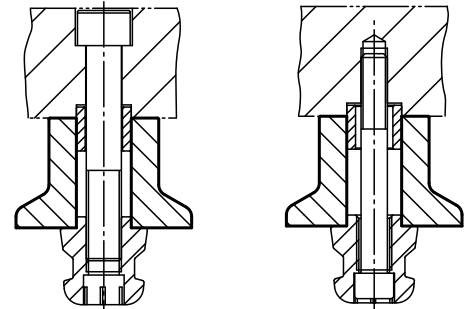

### KIPP UNI lock 5-axis reducer adapter

Order No. soft	Order No. hard	Form	D	H	H1
K0966.251100	K0966.251101	A	M10 x 75	25	25,5
K0966.252100	K0966.252101	B	M10 x 75	25	25,5
K0966.253100	K0966.253101	C	M10 x 75	25	25,5
K0966.501100	K0966.501101	A	M10 x 100	50	25,5
K0966.502100	K0966.502101	B	M10 x 100	50	25,5
K0966.503100	K0966.503101	C	M10 x 100	50	25,5
K0966.251120	K0966.251121	A	M12 x 75	25	27,5
K0966.252120	K0966.252121	B	M12 x 75	25	27,5
K0966.253120	K0966.253121	C	M12 x 75	25	27,5
K0966.501120	K0966.501121	A	M12 x 100	50	27,5
K0966.502120	K0966.502121	B	M12 x 100	50	27,5
K0966.503120	K0966.503121	C	M12 x 100	50	27,5

## UNI lock 5-axis reducer adapter

size 80 mm

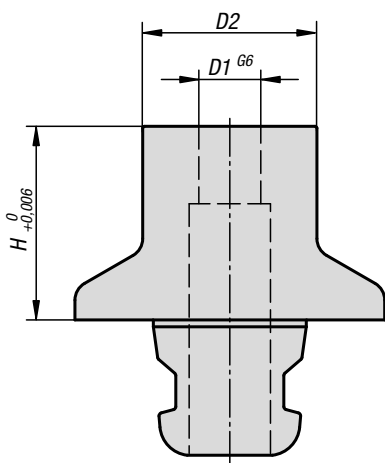

**Material:**

Steel.

**Version:**

Body oxidised.

Contact surfaces case-hardened and ground.

**Sample order:**

K0966.5011611

**Note:**

The UNI lock 5-axis reducer adapters are suitable for clamping and positioning workpieces.

The workpiece is positioned and screwed to the reducer adapter using the UNI lock shoulder screw for workpiece fastening.

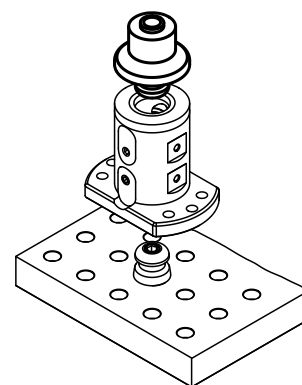

### KIPP UNI lock 5-axis reducer adapter

Order No.	D1	D2	H
K0966.5011211	12	40	50
K0966.5011611	16	40	50

## Angle clamp adapters

size 80 mm



**Material:**  
Steel.

**Version:**  
Main body oxidised.  
Contact faces case-hardened and ground.

**Sample order:**  
K1013.100100080

**Note:**  
The angle clamp adapter can be used to process workpieces in different processing levels. In doing so, the workpiece stays mounted on the angle clamping adapter.

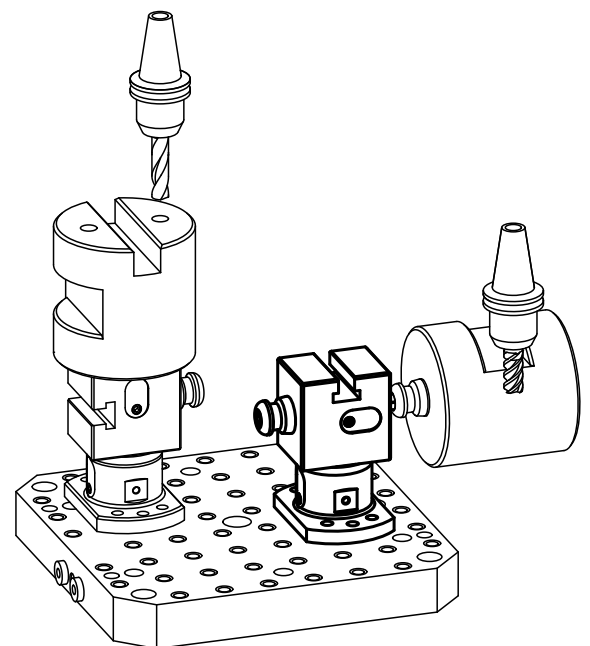
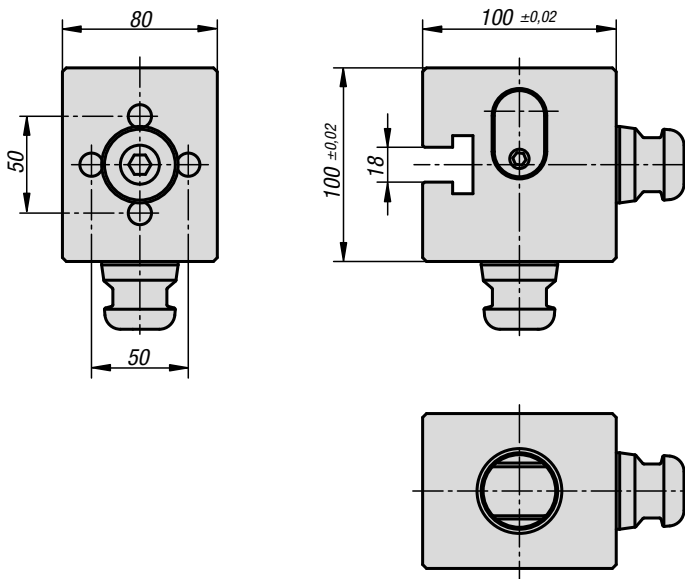

### KIPP Angle clamping adapter

Order No.	Dimensions	weight kg
K1013.100100080	see drawing	7.2

## UNI lock T-slot centring clamp bolt

size 80 mm

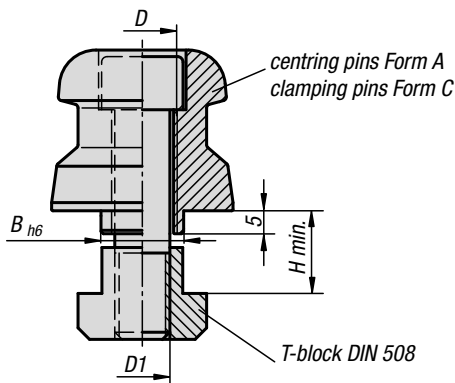

**Material:**

Steel.

**Version:**

Hardened and black oxidised.  
Contact faces ground.

**Sample order:**

K0969.114

**Note:**

The UNI lock T-slot centring clamp bolt is suitable for clamping and positioning the basic module with double manual clamping. T-slot centring clamp bolts are positioned and fastened on the T-slot machine table.

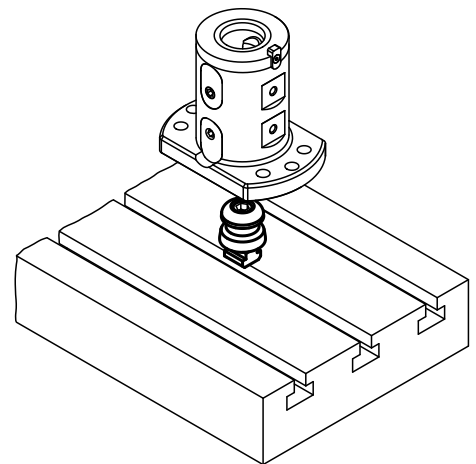

### KIPP UNI lock T-slot centring clamp bolt

Order No.	Form	D	D1	B	H min.
K0969.114	A	M12	M10	14	14
K0969.118	A	M16	M12	18	18
K0969.122	A	M16	M12	22	22
K0969.314	C	M12	M10	14	14
K0969.318	C	M16	M12	18	18
K0969.322	C	M16	M12	22	22

# UNI lock clamping pin

size 80 mm







**Material:**  
Steel.

**Version:**  
Hardened and black oxidised.  
Contact faces ground.

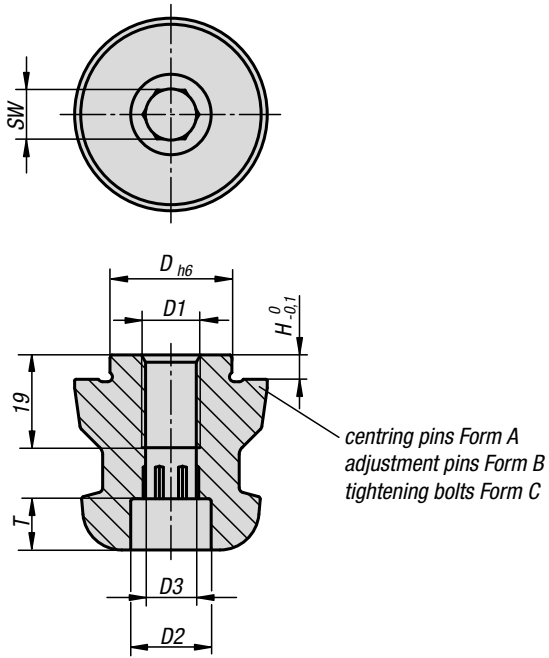
**Sample order:**  
K0967.140160512

**Note:**  
The UNI lock clamping pin is suitable for clamping and positioning workpieces and fixtures. Clamping pins are screwed onto the exchange element and adapted to the various basic modules.



-  Centring pins = Form A      fixes in x and y axis (reference point)
-  Adjustment pins = Form B      fixes the free axis (bayonet pin)
-  Tightening bolts = Form C      Pins with undersize (no centring function, clamping only)

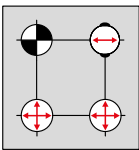

- 1 = fastening with grub screw DIN 913
- 2 = fastening with DIN 912 screw through the tightening bolt
- 3 = fastening with DIN 912 screw through the fixture or workpiece

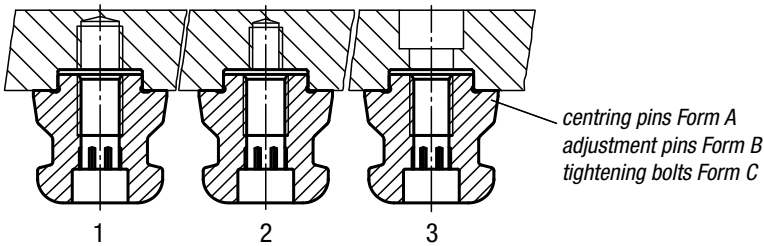

## UNI lock clamping pin

size 80 mm



## KIPP UNI lock clamping pin

Order No.	Form	D	D1	D2	D3	H	T	SW
K0967.140160512	A	16	M12	16,5	10,3	5	10,5	10
K0967.140180512	A	18	M12	16,5	10,3	5	10,5	10
K0967.140200512	A	20	M12	16,5	10,3	5	10,5	10
K0967.140220516	A	22	M16	18,5	14,2	5	12,5	17
K0967.140240516	A	24	M16	18,5	14,2	5	12,5	17
K0967.140250512	A	25	M12	16,5	10,3	5	10,5	10
K0967.140250516	A	25	M16	18,5	14,2	5	12,5	17
K0967.140251012	A	25	M12	16,5	10,3	10	10,5	10
K0967.140251016	A	25	M16	18,5	14,2	10	12,5	17
K0967.240160512	B	16	M12	16,5	10,3	5	10,5	10
K0967.240180512	B	18	M12	16,5	10,3	5	10,5	10
K0967.240200512	B	20	M12	16,5	10,3	5	10,5	10
K0967.240220516	B	22	M16	18,5	14,2	5	12,5	17
K0967.240240516	B	24	M16	18,5	14,2	5	12,5	17
K0967.240250512	B	25	M12	16,5	10,3	5	10,5	10
K0967.240250516	B	25	M16	18,5	14,2	5	12,5	17
K0967.240251012	B	25	M12	16,5	10,3	10	10,5	10
K0967.240251016	B	25	M16	18,5	14,2	10	12,5	17
K0967.340160512	C	16	M12	16,5	10,3	5	10,5	10
K0967.340180512	C	18	M12	16,5	10,3	5	10,5	10
K0967.340200512	C	20	M12	16,5	10,3	5	10,5	10
K0967.340220516	C	22	M16	18,5	14,2	5	12,5	17
K0967.340240516	C	24	M16	18,5	14,2	5	12,5	17
K0967.340250512	C	25	M12	16,5	10,3	5	10,5	10
K0967.340250516	C	25	M16	18,5	14,2	5	12,5	17
K0967.340251012	C	25	M12	16,5	10,3	10	10,5	10
K0967.340251016	C	25	M16	18,5	14,2	10	12,5	17

## UNI lock clamping pin

one-piece size 80 mm



**Material:**

Steel.

**Version:**

Hardened and black oxidised.  
Contact faces ground.

**Sample order:**

K0967.140323024

**Note:**

The UNI lock clamping pin is suitable for clamping and positioning workpieces and fixtures. Clamping pins are screwed onto the exchange element and adapted to the various basic modules.

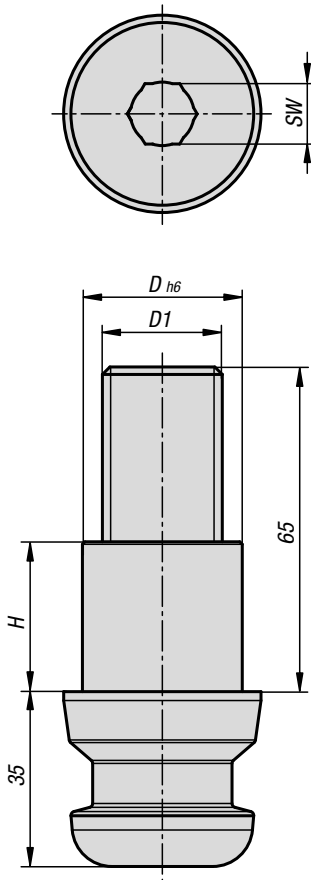

- Centring pins = Form A      fixes in x and y axis (reference point)
- Adjustment pins = Form B      fixes the free axis (bayonet pin)
- Tightening bolts = Form C      Pins with undersize (no centring function, clamping only)

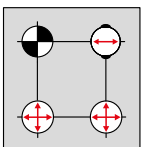

### KIPP UNI lock clamping pin, one-piece

Order No.	Form	D1	D	H	SW
K0967.140323024	A	M24	32	30	17
K0967.240323024	B	M24	32	30	17
K0967.340323024	C	M24	32	30	17



## UNI lock clamping pin

with threaded pin size 80 mm

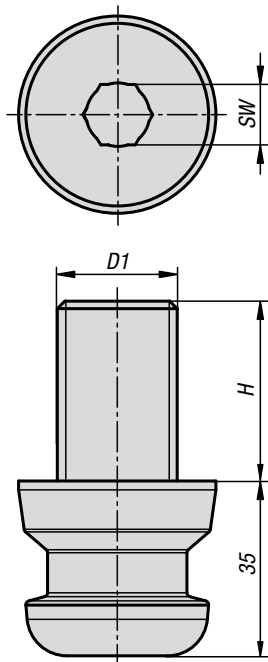

**Material:**

Steel.

**Version:**

Hardened and black oxidised.  
Contact faces ground.

**Sample order:**

K0967.140003020

**Note:**

The UNI lock clamping pin is suitable for clamping and positioning workpieces and fixtures. Clamping pins are screwed onto the exchange element and adapted to the various basic modules.

- Centring pins = Form A      fixes in x and y axis (reference point)
- Adjustment pins = Form B      fixes the free axis (bayonet pin)
- Tightening bolts = Form C      Pins with undersize (no centring function, clamping only)

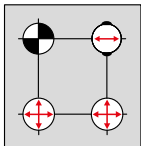

### KIPP UNI lock clamping pin with threaded pin

Order No.	Form	D1	H	SW
K0967.140002416	A	M16	24	17
K0967.140003020	A	M20	30	17
K0967.140003624	A	M24	36	17

## UNI lock clamping bolts

for fastening to workpieces size 80 mm

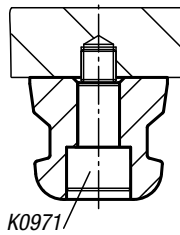
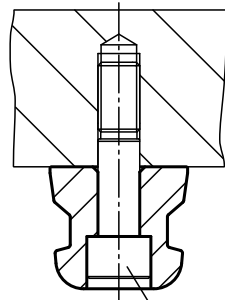
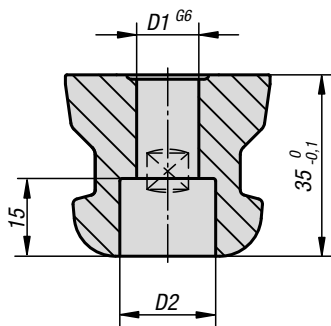
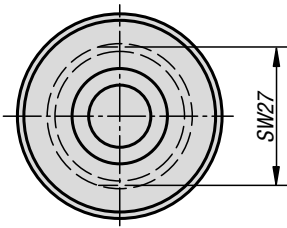

**Material:**  
Steel.

**Version:**  
Hardened and black oxidised.  
Contact faces ground.

**Sample order:**  
K0968.12

**Note:**  
The UNI lock clamping bolt is suitable for clamping and positioning the workpiece. Clamping bolts are screwed onto the workpiece and positioned on the basic module or add-on module. Using the locating bolts (K0970, K0971), the clamping bolts are screwed onto the workpiece.

### KIPP UNI lock clamping bolts for fastening to workpieces

Order No.	D1	D2
K0968.12	12	18,4
K0968.16	16	21,1

# K0970

## UNI lock 5-axis shoulder screws

size 80 mm

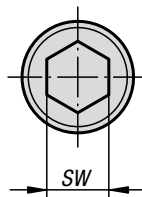
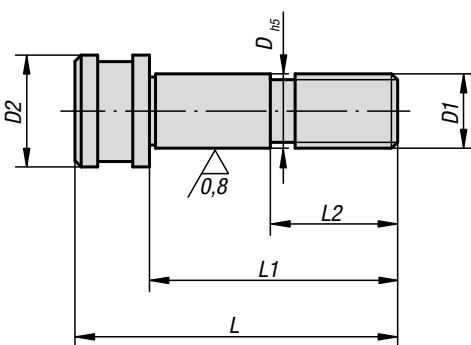

**Material:**  
Carbon steel.

**Version:**  
Hardened surface.  
ground locating seat.

**Sample order:**  
K0970.12050

**Note:**  
The UNI lock 5-axis locating bolts are suitable for clamping and positioning the clamping bolts for fastening to workpieces. They are also used for positioning and fastening the basic module.

### KIPP UNI lock 5-axis shoulder screws

Order No.	D	D1	D2	L	L1	L2	SW
K0970.12050	12	M12	18	62	50	22	10
K0970.16055	16	M16	24	71	55	25	14

## UNI lock 5-axis shoulder screws

for fastening to workpieces size 80 mm



**Material:**  
Carbon steel.

**Version:**  
Hardened surface.  
ground locating seat.

**Sample order:**  
K0971.1210040

**Note:**  
The UNI lock 5-axis locating bolts for fastening to workpieces are suitable for clamping and positioning workpieces. These locating bolts are passed through the clamping bolts for fastening to workpieces, screwed directly into the workpiece and positioned on the basic module or add-on module. The thread is used for fastening and positioning the workpiece.

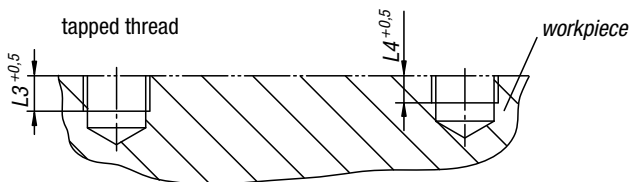
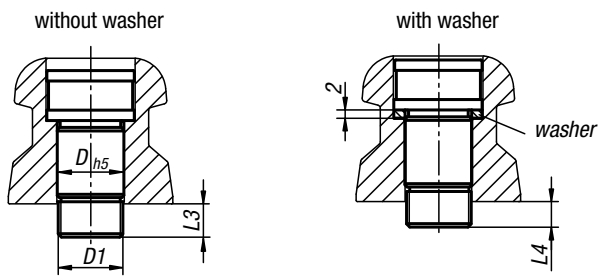
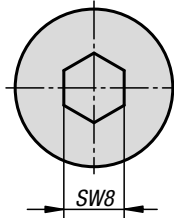
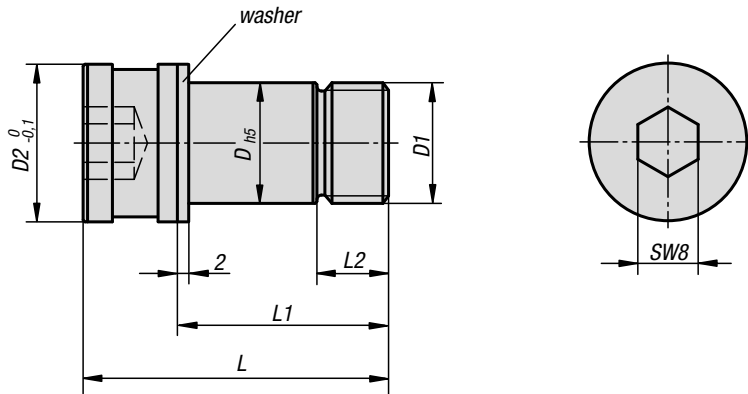

### KIPP UNI lock 5-axis shoulder screws for screwing clamping bolt to workpiece

Order No.	Version	D	D1	D2	L	L1	L2	L3	L4
K0971.1210040	with washer	12	M10x1,25	18	40,5	28	9,5	8	6
K0971.12101040	with washer	12	M10x1,5	18	40,5	28	9,5	8	6
K0971.1212040	with washer	12	M12x1,25	18	40,5	28	9,5	8	6
K0971.12121040	with washer	12	M12x1,75	18	40,5	28	9,5	8	6
K0971.1612040	with washer	16	M12x1,25	20,9	40,5	28	9,5	8	6
K0971.16121040	with washer	16	M12x1,75	20,9	40,5	28	9,5	8	6
K0971.16121049	without washer	16	M12x1,75	20,9	50	37,5	18	17,5	15,5
K0971.1616040	with washer	16	M16x1,25	20,9	40,5	28	9,5	8	6
K0971.16161040	with washer	16	M16x2	20,9	40,5	28	9,5	8	6
K0971.16161055	without washer	16	M16x2	20,9	56	43,5	24	23,5	21,5
K0971.16161067	without washer	16	M16x2	20,9	67,5	55	25	35	33

## Centring clamping bolts

size 80 mm



**Material:**

Steel.

**Version:**

Hardened and black oxidised.  
Contact faces ground.

**Sample order:**

K1012.1240

**Note:**

The centering clamping bolt can be used to position basic modules on machine tables. Centring clamping bolts can be clamped in collet holders. The position of the module is defined via the machine's spindle/control unit.

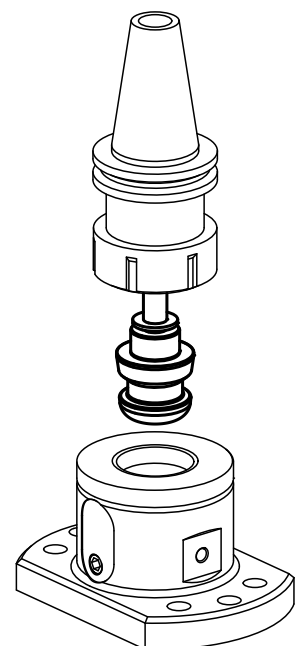
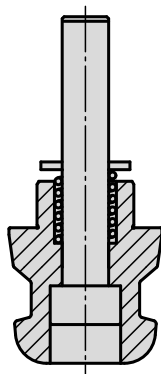
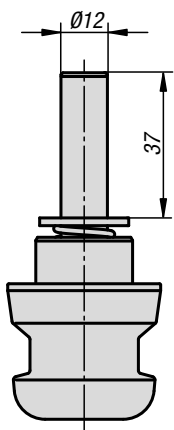

### KIPP Centring clamping bolt

Order No.	Dimensions
K1012.1240	see drawing



## Notes

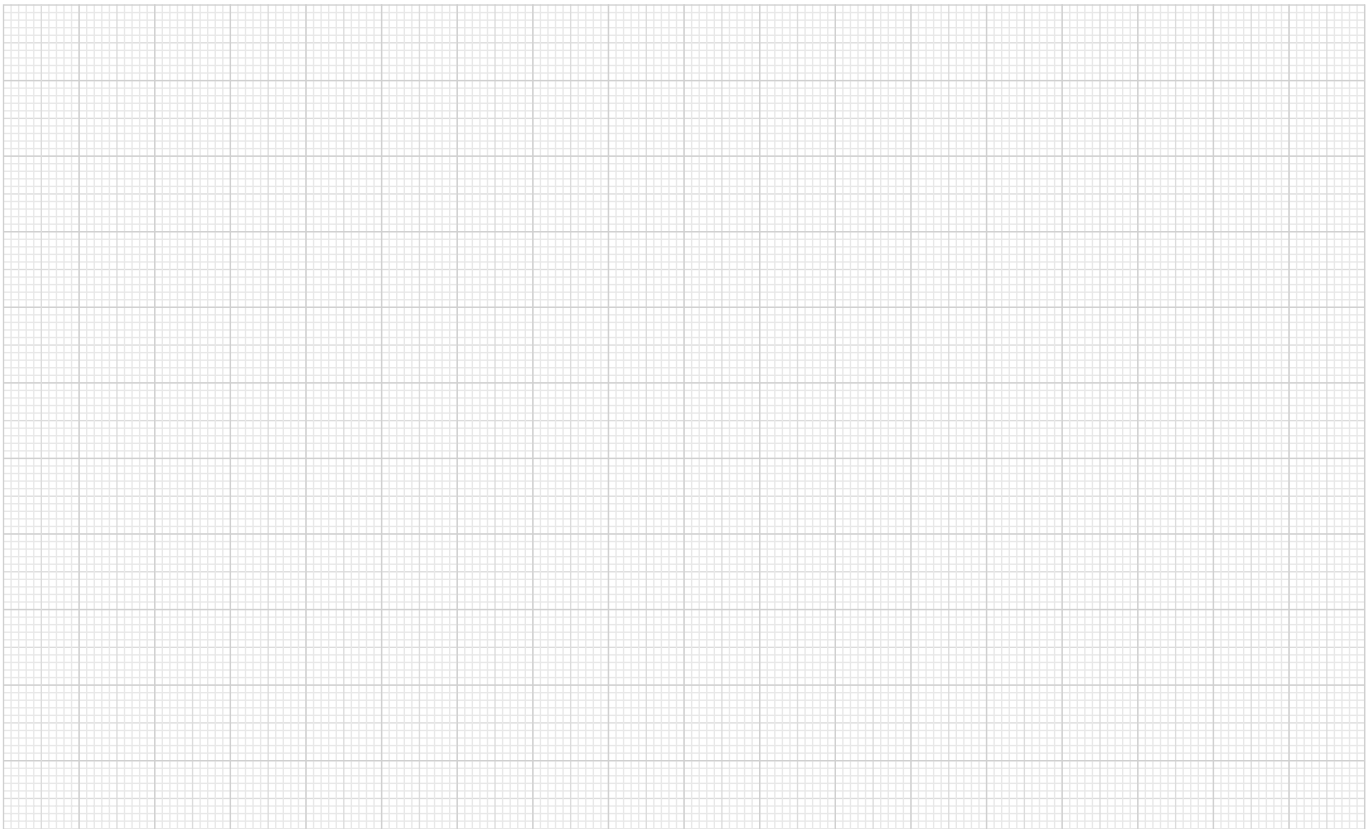



## 5-axis module clamping system 50



# Forces

System size 50 mm

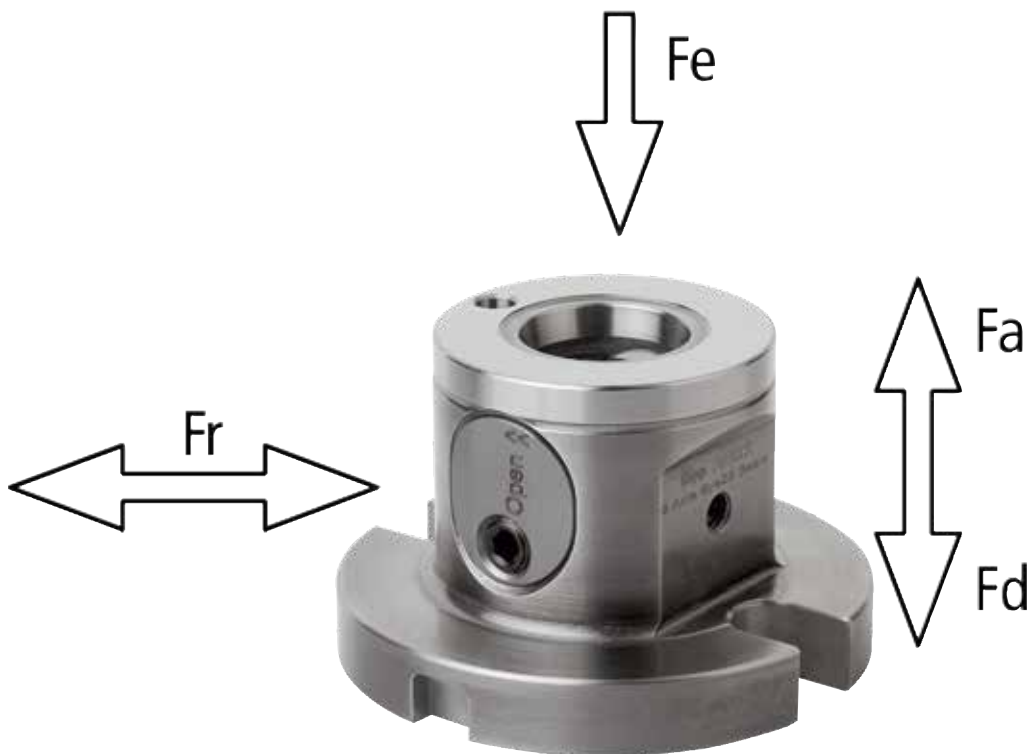

- Fr**    Permissible transverse force
- Fa**    Permissible clamping force
- Fd**    Permissible contact force
- Fe**    Clamping bolt pull-in force

**Permissible load with full contact:**

		Fr	Fa	Fd	Fe
Clamping pin screw M6	kN	15	20	25	8
Clamping pin screw M8	kN	15	25	25	10
Clamping pin screw M10	kN	15	30	25	12

**Note:** Forces apply at a max. tightening torque of 10 Nm.



# Function



The UNI lock clamping system 50 mm has been developed specifically for 5-side machining of small workpieces.

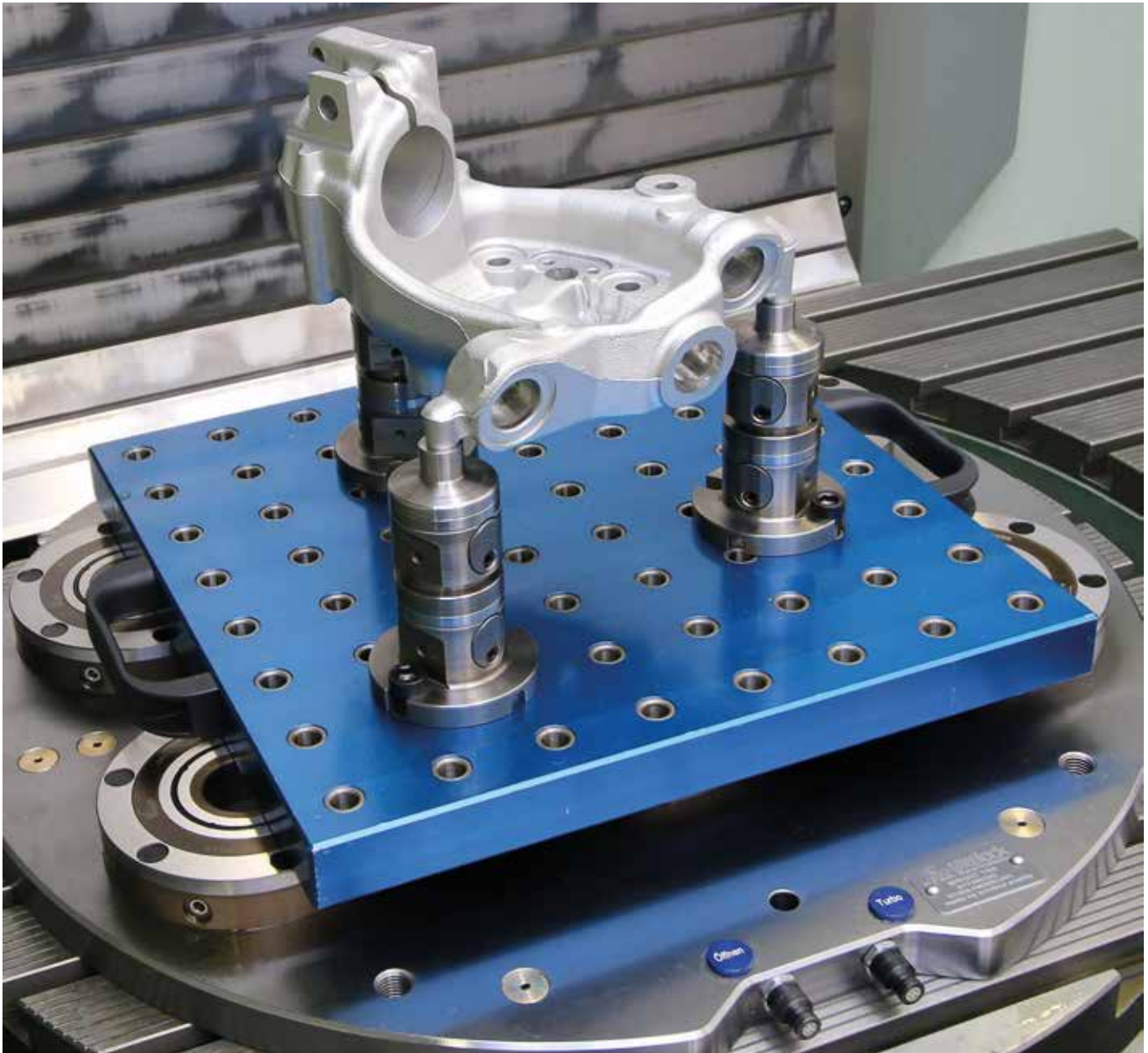

## Advantages:

- 5-side machining with no protruding edges
- Modular construction guarantees maximum flexibility
- Can be combined with the UNI lock modular system 80 mm
- Small gauges for modules from 40 mm possible
- Small clamping pin, D 25 mm, for workpieces with smaller dimensions
- Variable workpiece fastening
- The workpiece is simply positioned and clamped with screws or seatings
- High module clamping force
- Very high repeat accuracy

# UNI lock 5-axis basic module

system size 50 mm



**Material:**

Rust resistant tool steel.

**Version:**

Contact faces hardened and ground.

**Sample order:**

K1117.12050601

**Note:**

The UNI lock 5-axis basic module, system size 50 can be adapted to mount on machine tables with grid holes or T-slots, or on grid hole subplates. The system size 50 basic module can also be combined with the system size 80 modules, allowing smaller workpieces to be easily clamped with the module clamping system.

Matches UNI lock zero point clamping system with UNI lock D=18 mm clamping bolts.

Can also be mounted directly onto commonly available zero point clamping systems using suitable clamping bolts.

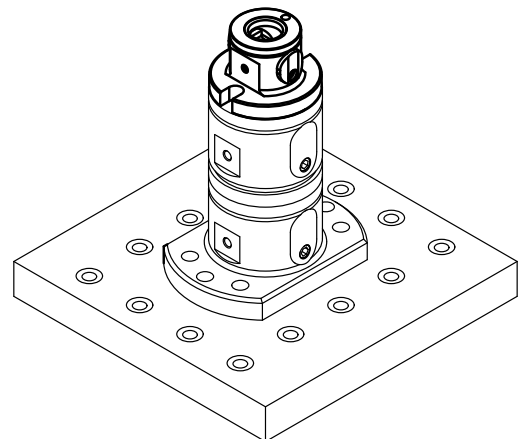
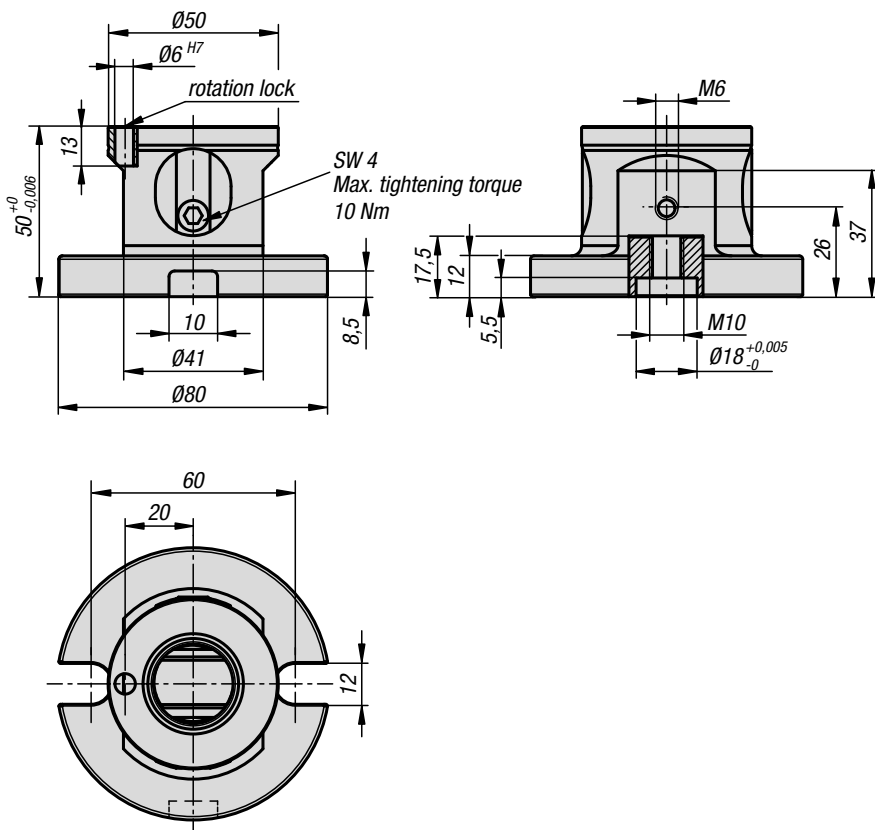

**KIPP UNI lock 5-axis basic module, system size 50 mm**

Order No.	Version
K1117.12050601	rotation lock

## UNI lock 5-axis basic module adjustable

system size 50 mm

**Material:**

Rust resistant tool steel.

**Version:**

Contact faces hardened and ground.

**Sample order:**

K1117.12072600

**Note:**

The UNI lock 5-axis basic module, system size 50 can be adapted to mount on machine tables with grid holes or T-slots, or on grid hole subplates. The system size 50 basic module can also be combined with the system size 80 modules, allowing smaller workpieces to be easily clamped with the module clamping system.

Matches UNI lock zero point clamping system with UNI lock D=18 mm clamping pins.

Can also be mounted directly onto commonly available zero point clamping systems if a suitable clamping pin is used..

Height adjustment with brass ring. Locking with a lateral lock screw. Workpieces with varying support face heights can be optimally supported and clamped.

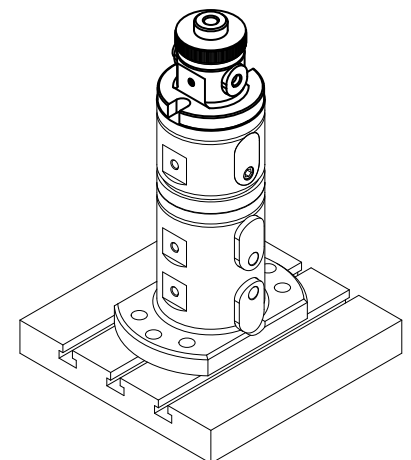
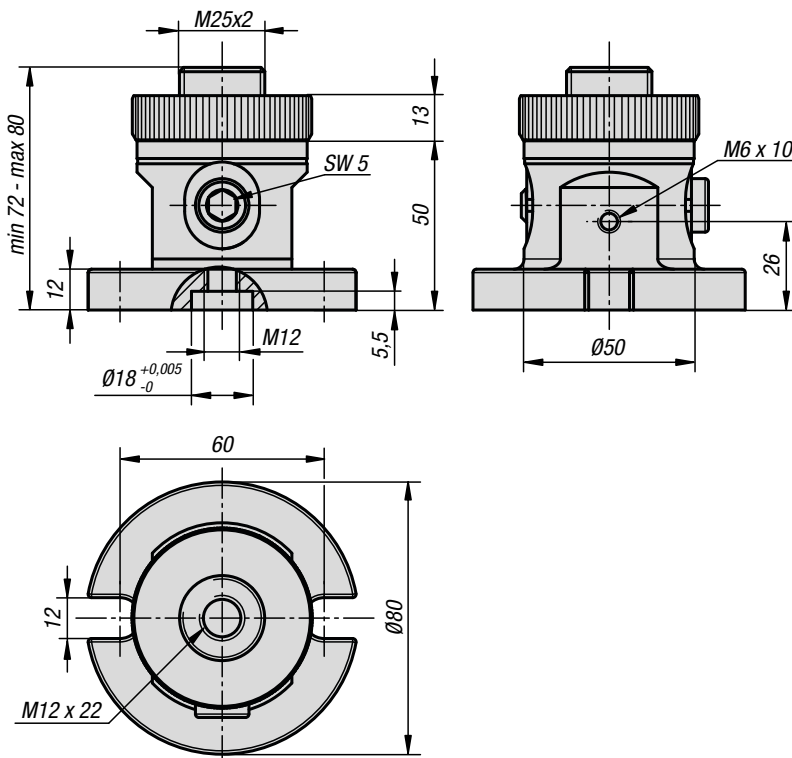

## KIPP UNI lock 5-axis basic module adjustable, system size 50 mm

Order No.

Version

K1117.12072600

adjustable

# UNI lock 5-axis basic module double clamp

system size 50 mm

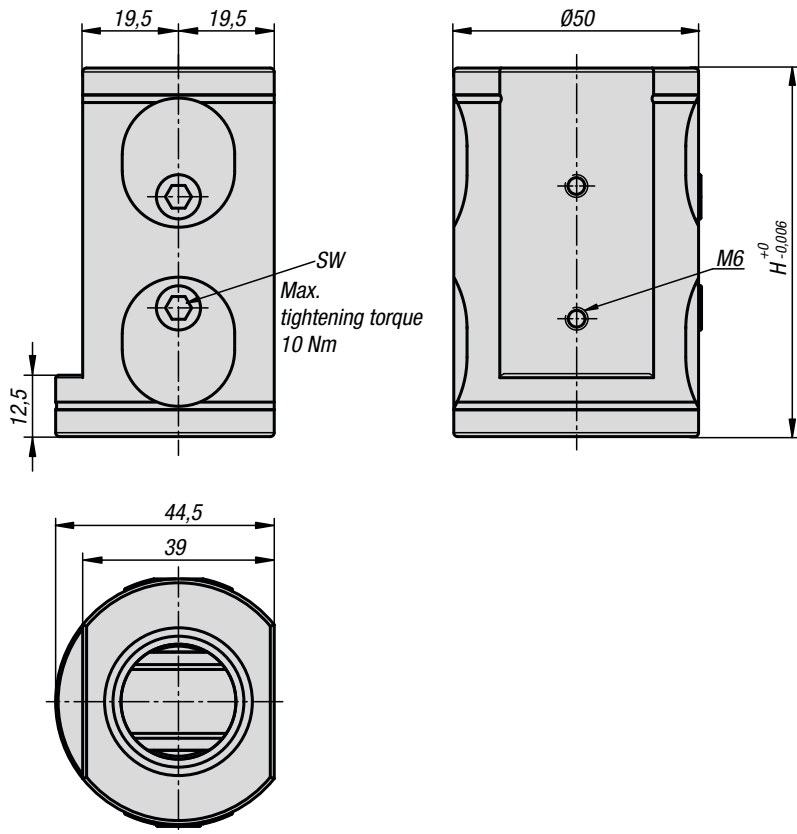

**Material:**

Rust resistant tool steel.

**Version:**

Contact faces hardened and ground.

**Sample order:**

K1118.000750

**Note:**

The UNI lock 5-axis double clamp basic modules can be adapted directly to machine tables with grid holes or T-slots, as well as grid hole subplates.

The narrow design of the basic module enables it to be used on grid spacings from 20 mm.

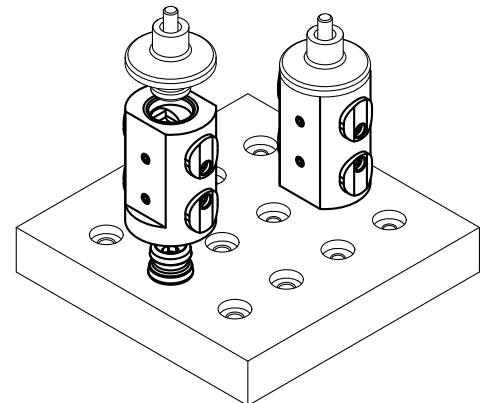
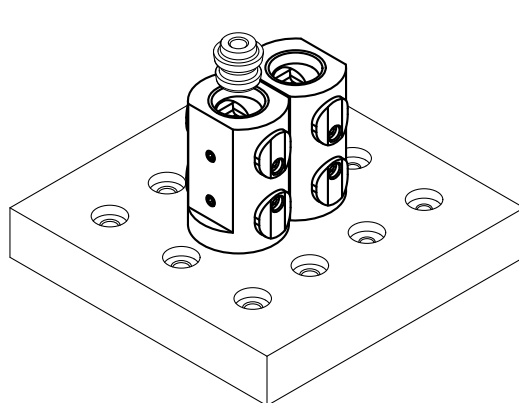

**KIPP UNI lock 5-axis basic module, double clamp, system size 50 mm**

Order No.	H	SW
K1118.000750	75	4

## UNI lock 5-axis add-on module

system size 50 mm

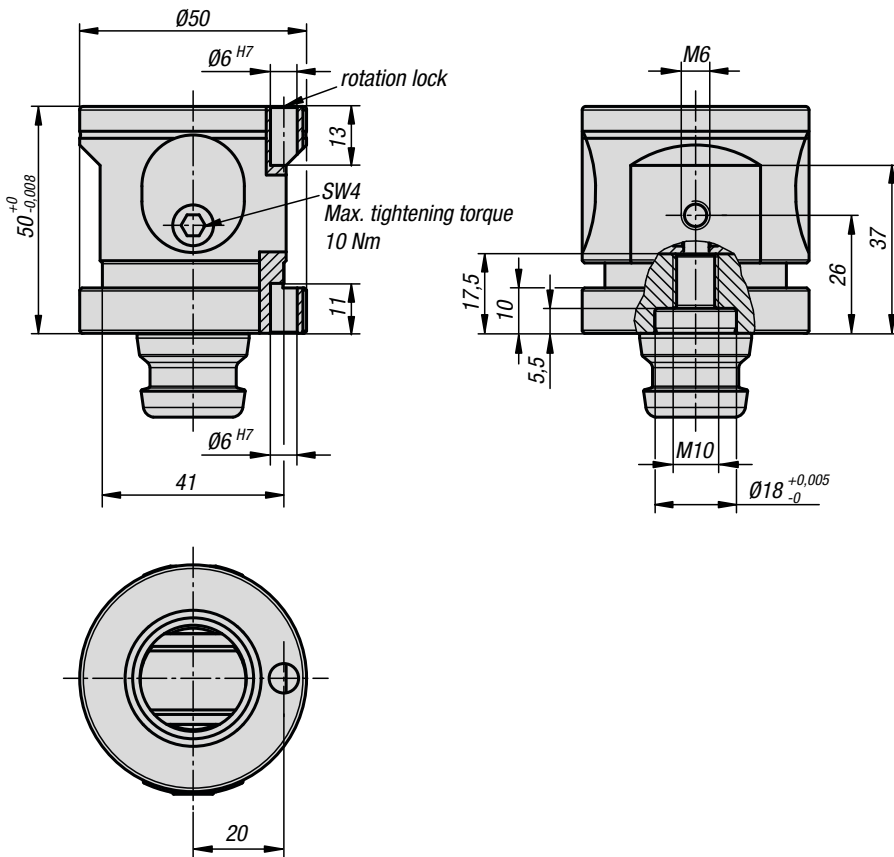

**Material:**  
Rust resistant tool steel.

**Version:**  
Contact faces hardened and ground.

**Sample order:**  
K1119.0501

**Note:**  
The UNI lock 5-axis add-on modules serve to raise the height of the basic modules and other add-on modules. Depending on the clamping situation, a combination of the basic modules and the add-on modules can be used to achieve the optimum clamping height. The system size 50 add-on module can also be combined with the system size 80.

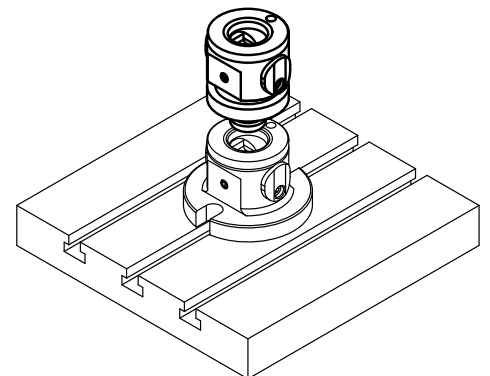

### KIPP UNI lock 5-axis add-on module, system size 50 mm

Order No.	Version
K1119.0501	rotation lock

# UNI lock 5-axis add-on module adjustable

system size 50 mm



**Material:**

Rust resistant tool steel.

**Version:**

Contact faces hardened and ground.

**Sample order:**

K1119.0720

**Note:**

UNI lock 5-axis add-on clamp modules are used for raising basic modules and mounting bases. Depending on the clamping situation, optimum assembly height can be achieved using a combination of basic module and add-on module. The system size 50 add-on module can also be combined with the system size 80.

Height adjustment with brass ring. Locking with a lateral lock screw. Workpieces with varying support face heights can be optimally supported and clamped.

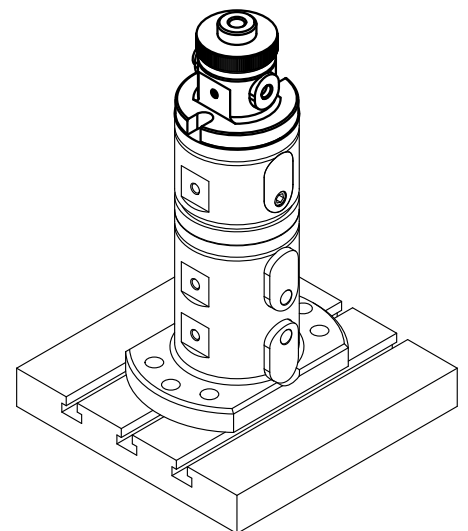
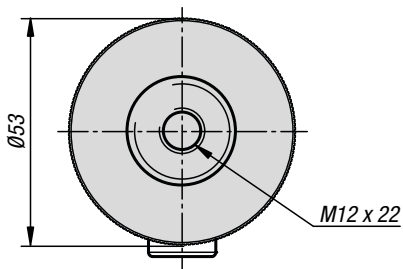
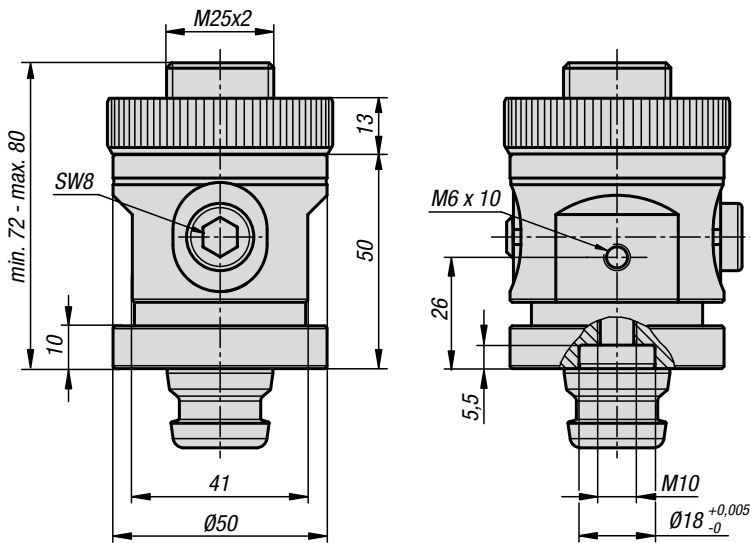

**KIPP UNI lock 5-axis add-on module adjustable, system size 50 mm**

Order No.	Version
K1119.0720	adjustable

# UNI lock 5-axis reducer adapter

system size 50 mm



**Material:**

Rust resistant tool steel.

**Version:**

Contact faces hardened and ground.

**Sample order:**

K1120.251081

**Note:**

The UNI lock 5-axis reducer adapter is suitable for clamping and positioning workpieces.

Reducer adapters can be screwed onto the workpiece and mounted on the basic module or add-on clamp module.

The system size 50 add-on module can also be combined with the system size 80.

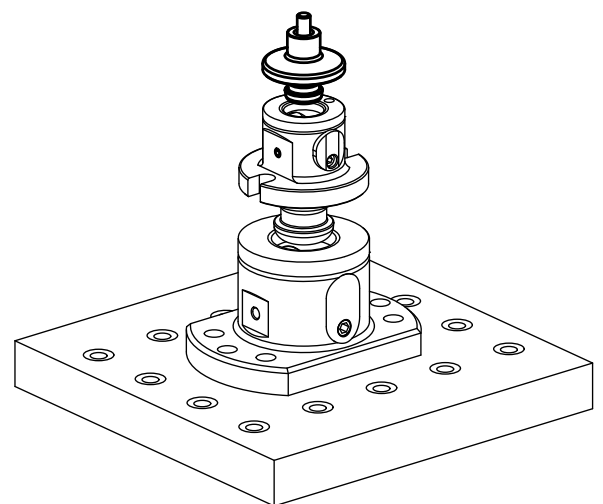
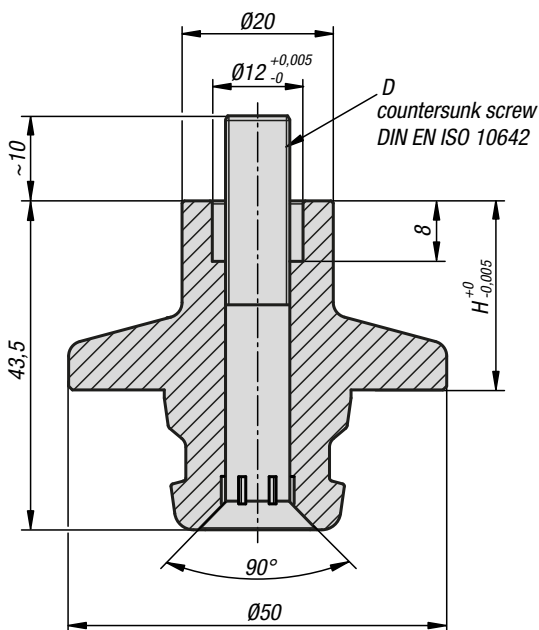

**KIPP UNI lock 5-axis reducer adapter, system size 50 mm**

Order No.	Form	D	H
K1120.251081	A	M8	25

## UNI lock clamping pin

system size 50 mm

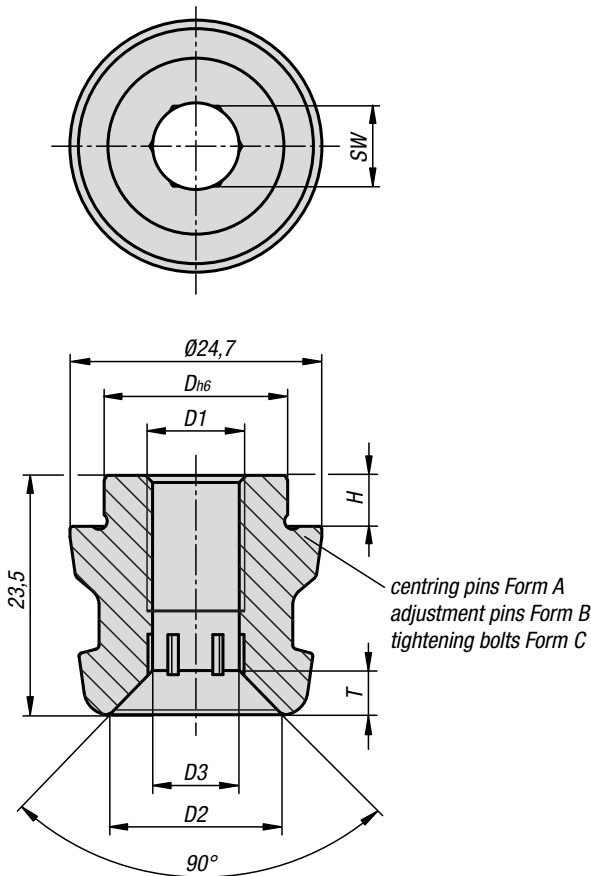

**Material:**

Rust resistant tool steel.

**Version:**



Contact faces hardened and ground.

**Sample order:**

K1121.125180510

**Note:**

The UNI lock clamping pin is suitable for clamping and positioning workpieces and fixtures. Clamping pins are screwed onto the exchange element and adapted to the various basic modules.

-  Centring pins = Form A      fixes in x and y axis (reference point)
-  Adjustment pins = Form B      fixes the free axis (bayonet pin)
-  Tightening bolts = Form C      Pins with undersize (no centring function, clamping only)

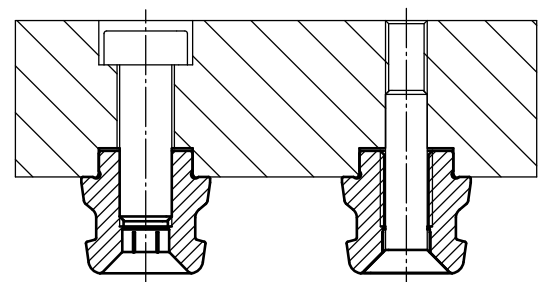
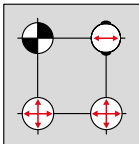

### KIPP UNI lock clamping pin, system size 50 mm

Order No.	Form	D1	D	D2	D3	H	T	SW
K1121.125180510	A	M10	18	16,5	9	5	5	8
K1121.225180510	B	M10	18	16,5	9	5	5	8
K1121.325180510	C	M10	18	16,5	9	5	5	8



# Application example



## Notes

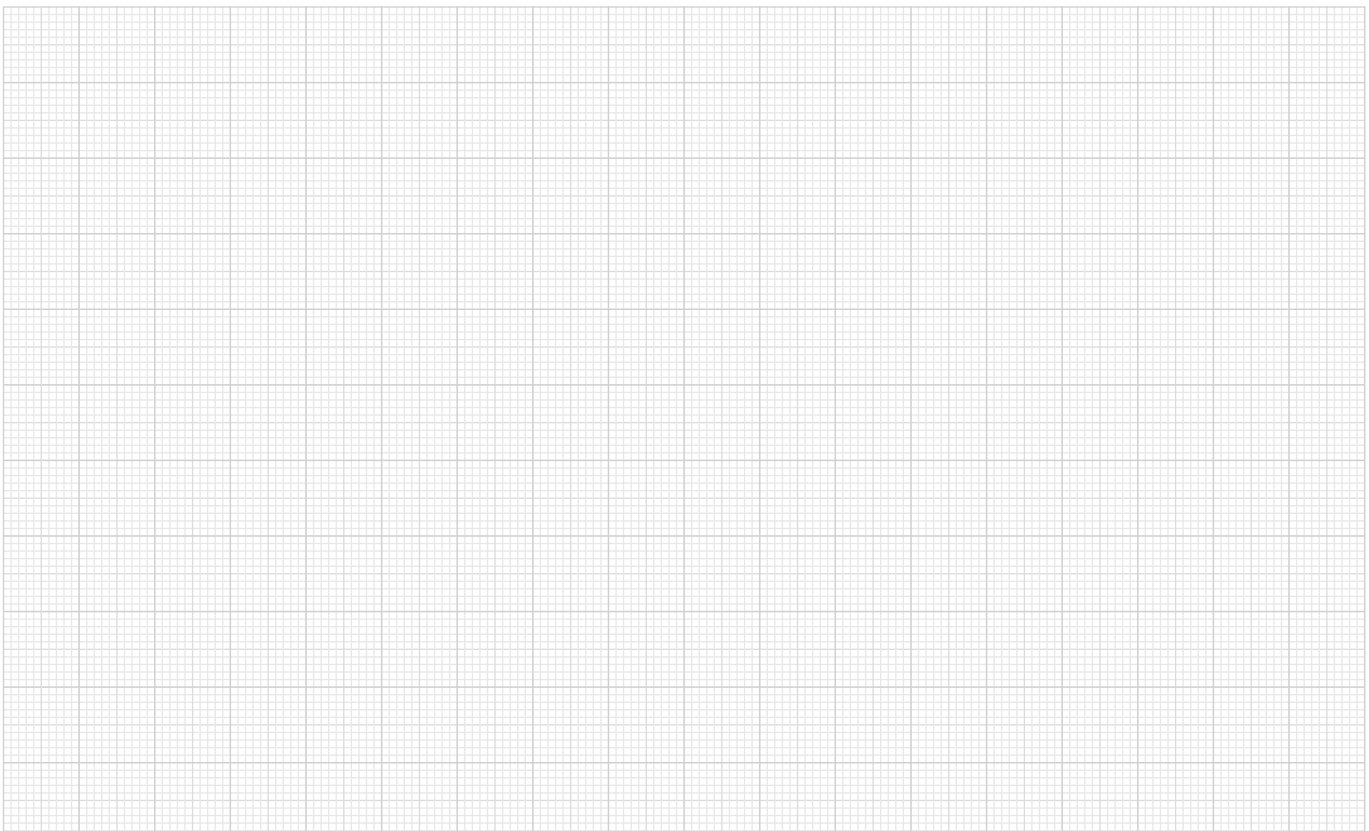



## 5-axis module clamping system 138





# Forces

System size 138 mm

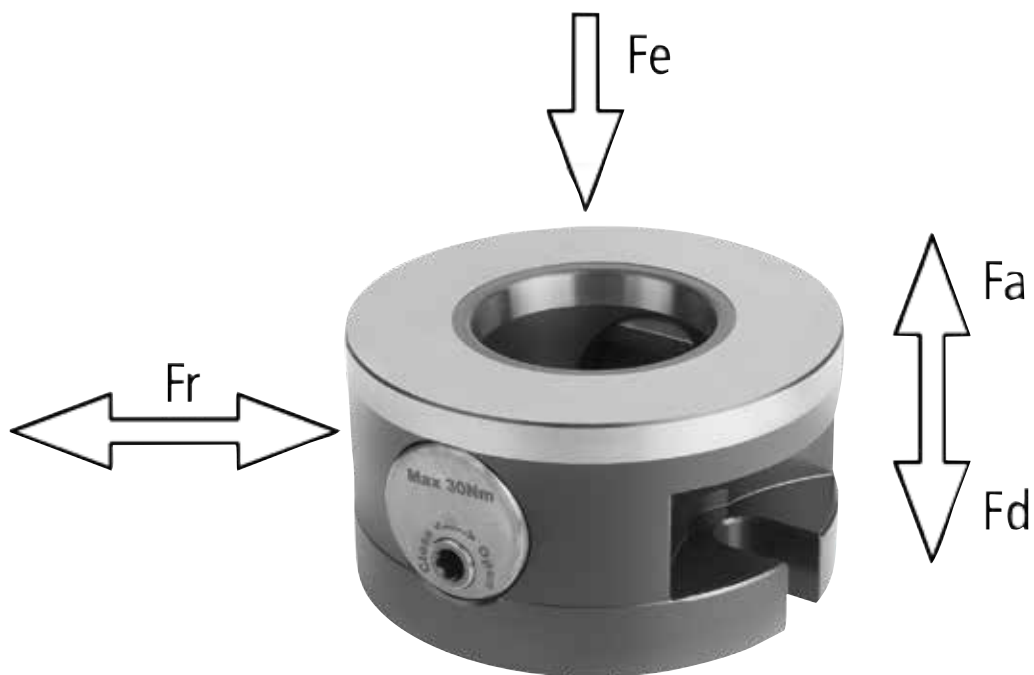

- Fr** Permissible transverse force
- Fa** Permissible clamping force
- Fd** Permissible contact force
- Fe** Clamping bolt pull-in force

## Permissible load with full contact:

		Fr	Fa	Fd	Fe
Clamping pin screw M24	kN	60	100	100	40

**Note:** Forces apply at a max. tightening torque of 30 Nm.

## UNI lock 5-axis basic module

system size 138 mm



**Material:**  
Steel.

**Version:**  
Main body oxidised.  
Contact faces case-hardened and ground.

**Sample order:**  
K1419.1380750

**Note:**

The UNI lock 5-axis basic modules in size 138 are suitable for clamping large and heavy workpieces. The workpieces can be inserted directly into the basic module with the clamping pin or with the reducer adapter. The basic modules are screwed in place via the associated baseplates or directly to the machine table. They can be positioned in various ways. By placing two modules together, base to base, it is possible to create and use a double clamping module.

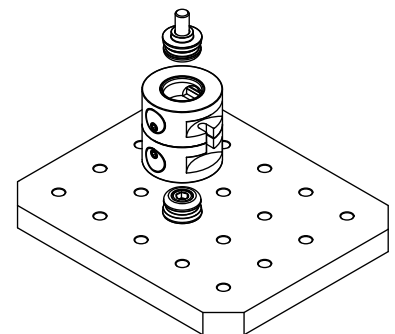
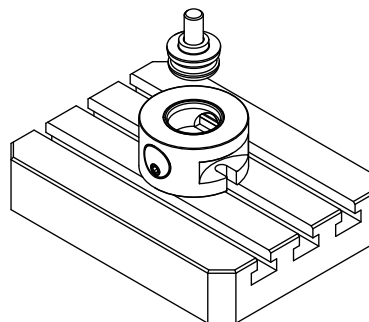
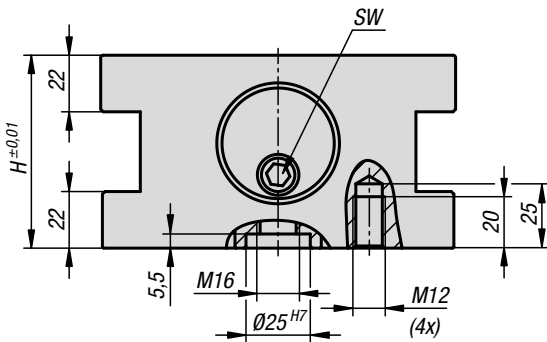
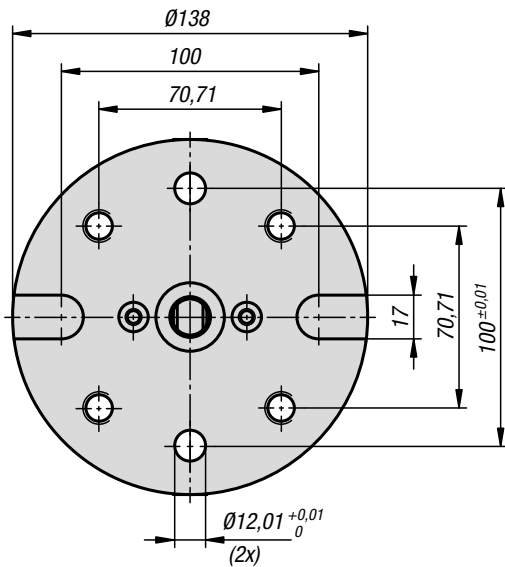

### KIPP UNI lock 5-axis basic module, system size 138 mm

Order No.	Version	H	SW	Tightening torque max. Nm
K1419.1380750	without rotation lock	75	8	30

# UNI lock 5-axis baseplate

for general clamping, size 138 mm

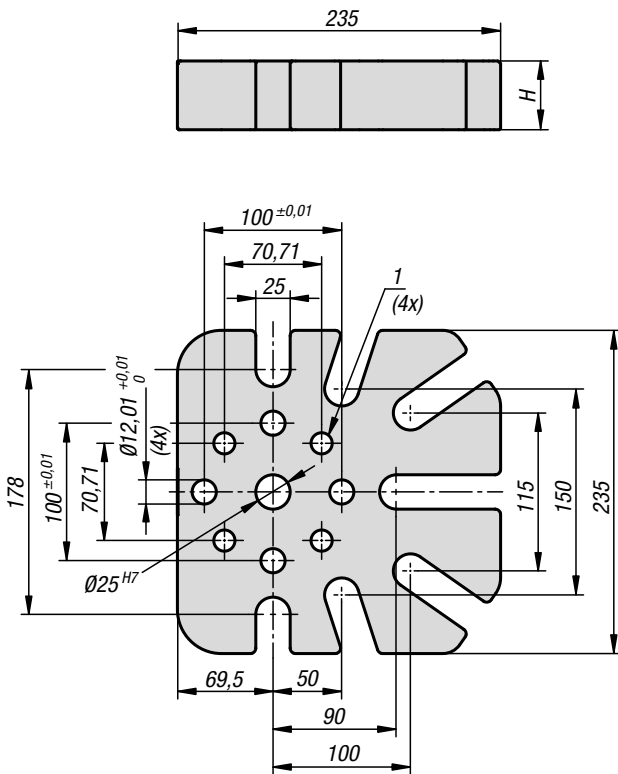

**Material:**

Steel.

**Version:**

Main body oxidised.

Contact faces case-hardened and ground.

**Sample order:**

K1420.23523505025

**Note:**

The UNI lock baseplates can be easily adapted to machine tables with T-slots or hole patterns. Due to their variable designs, these baseplates can be positioned flexibly on the machine table. As a result, the baseplates can be placed on the machine table in any position.

Due to their sturdy design, these baseplates are ideal for use as a basic element for large and heavy workpieces.

**On request:**

Other versions.

**Drawing reference:**

1) for DIN 912 M12 cap screw

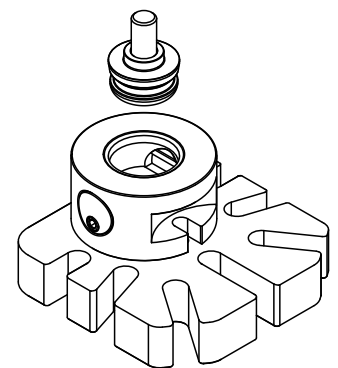

**KIPP UNI lock 5-axis baseplate for general clamping, size 138 mm**

Order No.	H
K1420.23523505025	50

## UNI lock 5-axis reducer adapter

system size 138 mm

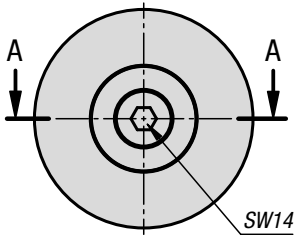

**Material:**

Steel.

**Version:**

Main body oxidised.

Contact faces case-hardened and ground.

**Sample order:**

K1422.0501241080

**Note:**

The UNI lock 5-axis reducer adapter is suitable for clamping and positioning workpieces.

Reducer adapters can be screwed onto the workpiece and mounted on the basic module or add-on clamp module.

**On request:**

Other versions.

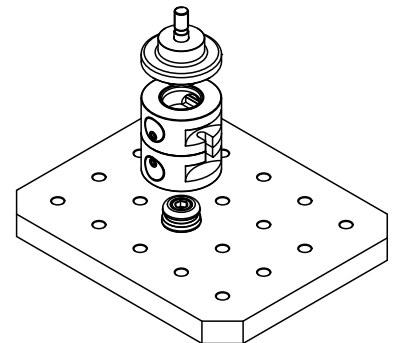
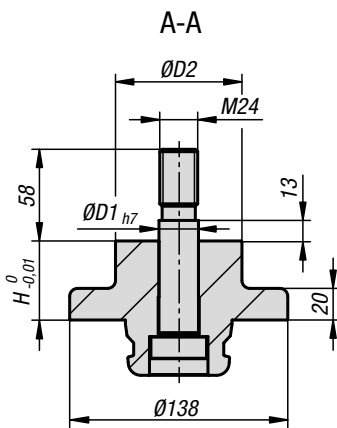

**KIPP UNI lock 5-axis reducer adapter, system size 138 mm**

Order No.	D1	D2	H
K1422.0501241080	25	80	50



## UNI lock 5-axis reducer adapter

system size 138 mm

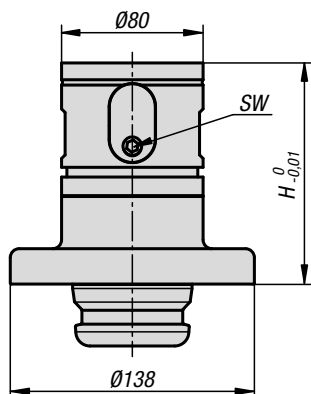

**Material:**

Steel.

**Version:**

Main body oxidised.

Contact faces case-hardened and ground.

**Sample order:**

K1423.1251

**Note:**

The UNI lock 5-axis reducer adapters are used to convert from size 80 to size 138.

They therefore allow all size 80 elements to continue to be used.

**On request:**

Other versions.

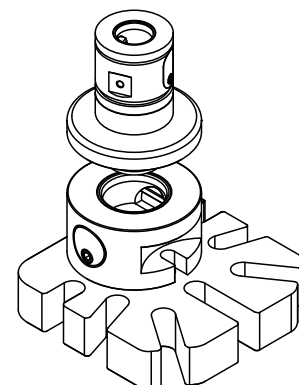

**KIPP UNI lock 5-axis reducer adapter, system size 138 mm**

Order No.	H	SW	Holding force F kN	Tightening torque max. Nm
K1423.1251	125	6	50	15

## UNI lock clamping pin

system size 138 mm

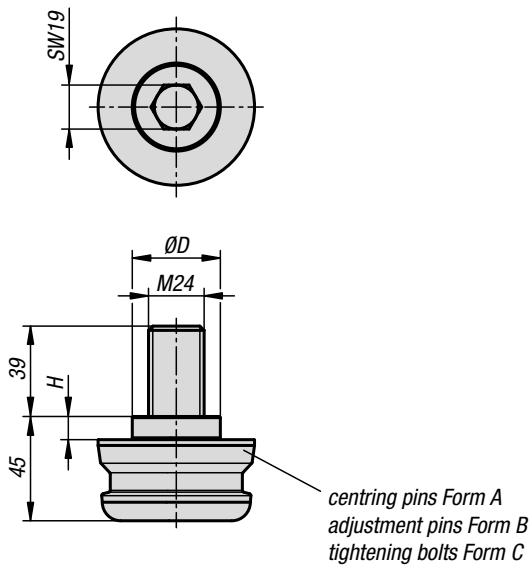

**Material:**  
Steel.

**Version:**  
Main body oxidised.  
Contact faces case-hardened and ground.

**Sample order:**  
K1424.168381025

**Note:**  
The UNI lock clamping pins are suitable for clamping and positioning workpieces and fixtures. The clamping pins are screwed onto the exchange element.

**On request:**  
Other versions.

- Centring pins = Form A      fixes in x and y axis (reference point)
- ⊖ Adjustment pins = Form B      fixes the free axis (bayonet pin)
- ⊕ Tightening bolts = Form C      Pins with undersize (no centring function, clamping only)

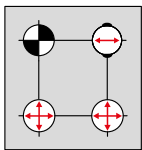

1 = fastening with DIN 912 screw through the tightening bolt

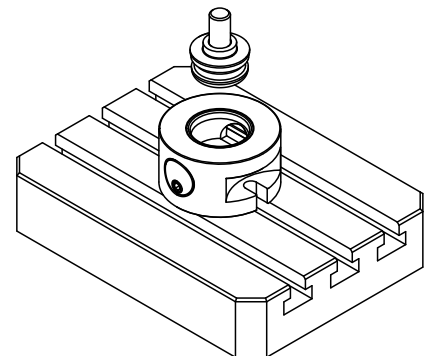
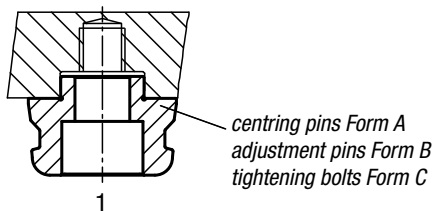

### KIPP UNI lock clamping pin, system size 138 mm

Order No.	Form	D	H
K1424.168381025	A	38	10
K1424.268381025	B	38	10
K1424.368381025	C	38	10

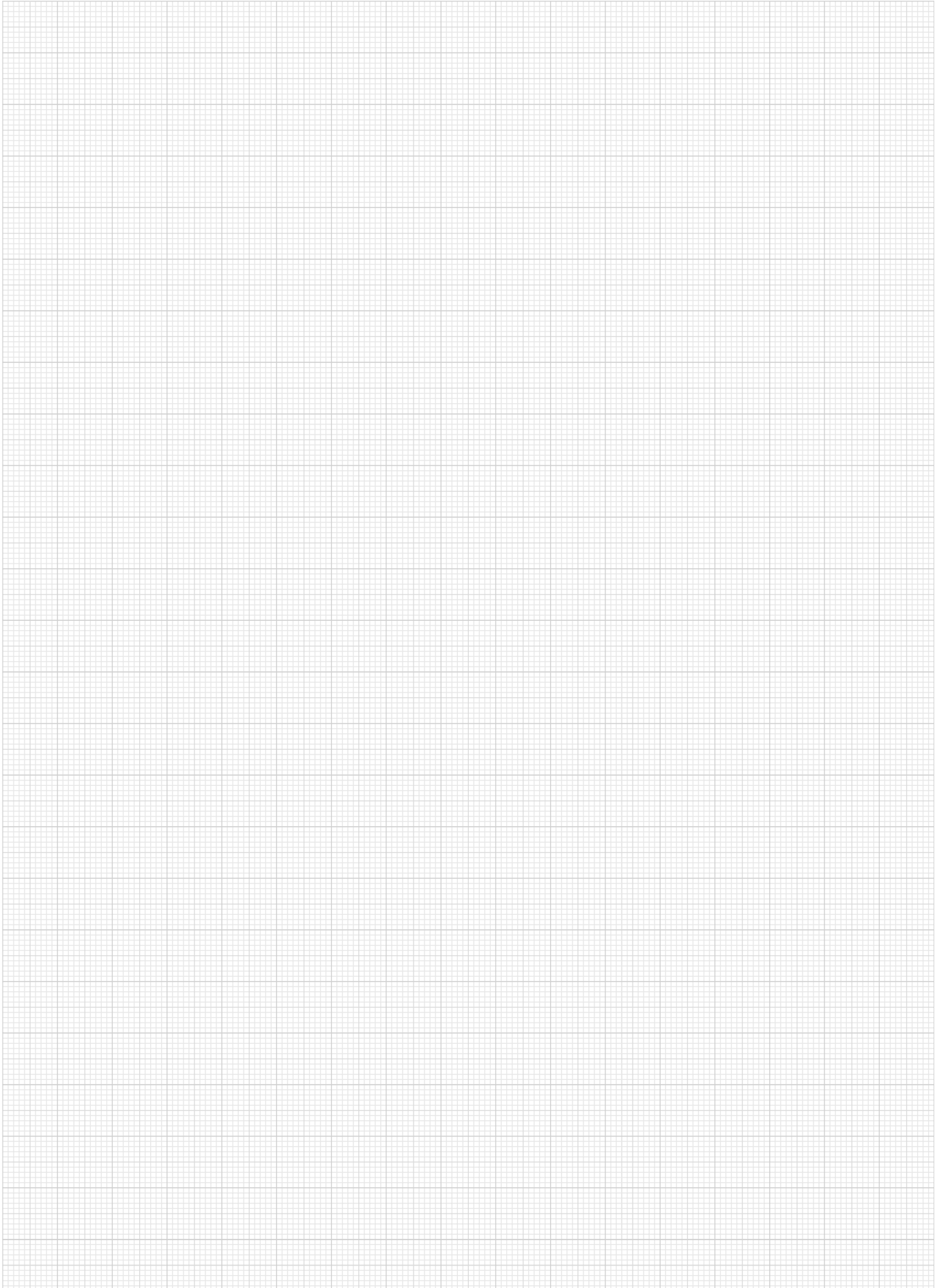



## Locating and clamping systems



# Locating and clamping system, mechanical

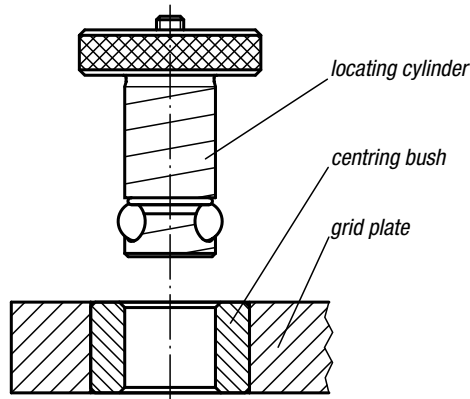

**recommended installation**

**alternative installation**

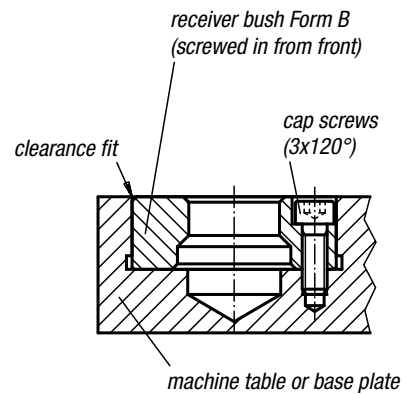
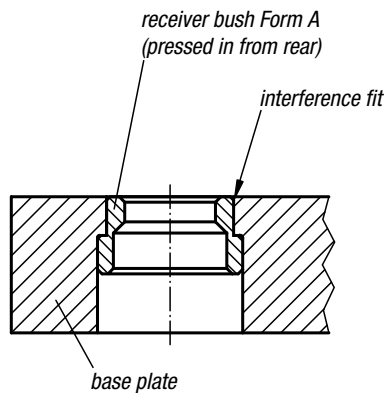

## General information

1. With the mechanical locating and clamping system, base and tooling plates can be precisely positioned and fastening in a couple of seconds. The system consists of a locating cylinder, a centring bush and a receiver bush.
2. Three easy steps to applying the positioning and clamping system: Mount two receiver bushes on the machine table or on the base plate, and two centring bushes on the clamping plate. Insert the locating cylinder through the centring bush into the receiver bush to attain precise positioning. Turn the set screws in each locating cylinder roughly two rotations to clamp tight. Eighteen different locating cylinders, two centring bush types and two receiver bush models are available.
3. A centring bush grade I (below left) and a centring bush grade I or II (above right) should be installed in each fastening plate as far apart from one another as possible. More than two positioning points bring no further advantages.  
When more than two locating cylinders are used for additional holding force (dependent on application), holes in the fastening plate must be 0.4 mm to 0.8 mm bigger than the selected locating cylinder diameter.
4. If the centre distance between the two positioning holes in the e.g. machine table and the clamping plate is kept within a tolerance of  $\pm 0.005$  mm and two centring bushings grade I are used, a repeat accuracy within  $\pm 0.013$  mm can be achieved.  
For a somewhat lower repeat accuracy within  $\pm 0.04$  mm, one centring bushing grade I and one centring bushing grade II with a centre distance tolerance of  $\pm 0.03$  mm are used.
5. The difference between the centring bush grade I and the centring bush grade II is that the centring bush grade II has a larger internal diameter in order to correspond to the greater centre distance tolerance in the machine table or the base plate.

## Locating cylinder

Ball Lock



**Material:**

Locating cylinder carbon steel.  
Balls roller bearing steel.

**Version:**

Locating cylinder tempered, black oxidised.  
Balls hardened, bright.

**Sample order:**

K0935.16020

**Note:**

By tightening the thrust screw (D2) the centre ball is pressed downwards and in turn forces the three locking balls outwards, where they locked in the receiver bush.

**With this easy to use system machine set-up times are up to twelve times shorter than when conventional methods are used.**

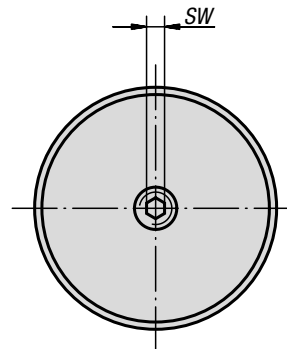
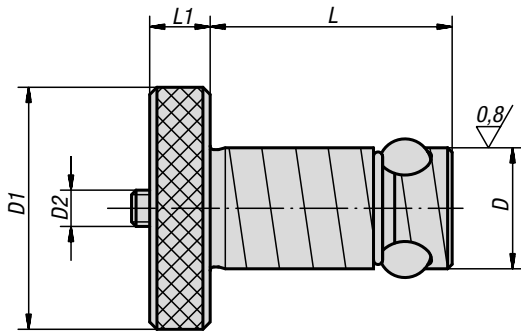

### KIPP Locating cylinders Ball lock

Order No.	Grid plate thickness $\pm 0,05$	D	D1	D2	L	L1	SW	Holding force F kN	Tightening torque max. Nm	Order No. Repair Kit
K0935.13013	13	13	22	M5	27,6	6	2,5	3,3	1	K0935.913013
K0935.13020	20	13	22	M5	34,6	6	2,5	3,3	1	K0935.913020
K0935.16020	20	16	32	M6	36,5	8	3	5,3	3	K0935.916020
K0935.16025	25	16	32	M6	41,5	8	3	5,3	3	K0935.916025
K0935.20020	20	20	40	M6	39,5	10	3	13,3	4	K0935.920020
K0935.20025	25	20	40	M6	44,5	10	3	13,3	4	K0935.920025
K0935.25020	20	25	45	M8	44	10	4	30	9	K0935.925020
K0935.25025	25	25	45	M8	49	10	4	30	9	K0935.925025
K0935.30020	20	30	50	M10	49	13	5	44	15	K0935.930020
K0935.30025	25	30	50	M10	54	13	5	44	15	K0935.930025
K0935.35020	20	35	60	M12	51	13	6	68	25	K0935.935020
K0935.35025	25	35	60	M12	56	13	6	68	25	K0935.935025
K0935.35040	40	35	60	M12	71	13	6	68	25	K0935.935040
K0935.35050	50	35	60	M12	81	13	6	68	25	K0935.935050
K0935.50020	20	50	75	M20	64	20	10	88	50	K0935.950020
K0935.50025	25	50	75	M20	69	20	10	88	50	K0935.950025
K0935.50040	40	50	75	M20	84	20	10	88	50	K0935.950040
K0935.50050	50	50	75	M20	94	20	10	88	50	K0935.950050

## Locating cylinder

with quick clamping system



**Material:**

Locating cylinder carbon steel.  
Balls roller bearing steel.

**Version:**

Locating cylinder tempered, black oxidised.  
Balls hardened, bright.

**Sample order:**

K0935.112013

**Note:**

Locating cylinder with quick-clamp system for extra timesaving during setups.

Insert the locating cylinder into the receiving hole and press the button. The three balls are pushed out and position the components. By tightening the set screw a 1/4 turn using an hexagonal key, the components are positively and securely held.

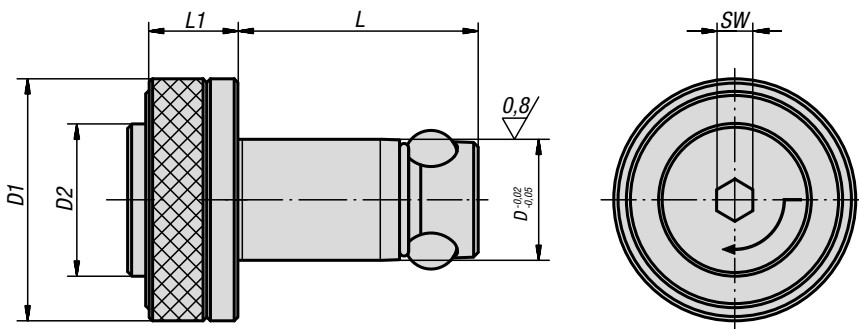

### KIPP Locating cylinder with quick clamping system

Order No.	Grid plate thickness ±0,05	D	D1	D2	L	L1	SW	Holding force F kN	Tightening torque max. Nm
K0935.113020	20	13	25	16	34,6	12	4	4	1
K0935.116020	20	16	32	20	36,5	15	6	8	2
K0935.120020	20	20	40	25	39,5	15	6	8	2
K0935.120025	25	20	40	25	44,5	15	6	8	2
K0935.116025	25	16	32	20	41,5	15	6	8	2
K0935.113013	13	13	25	16	27,6	12	4	4	1



## Centring bushes



**Material:**  
Ball bearing steel

**Version:**  
Hardened, black oxidised.

**Sample order:**  
K0936.113020

**Note:**  
By a centre distance tolerance of  $\pm 0.005$  mm and two grade I centring bushes a repeat accuracy of  $\pm 0.013$  mm is possible.  
By a centre distance tolerance of  $\pm 0.03$  mm and one grade I centring bush and one grade II centring bush repeat accuracy of  $\pm 0.04$  mm is possible.  
The centring bush is pressed with light pressure into the receiver holes in tooling plates.  
For further details see „General information“.

\* Tol. for grade I centring bushes  $+0.005 / +0.018$   
Tol. for grade II centring bushes  $+0.025 / +0.050$

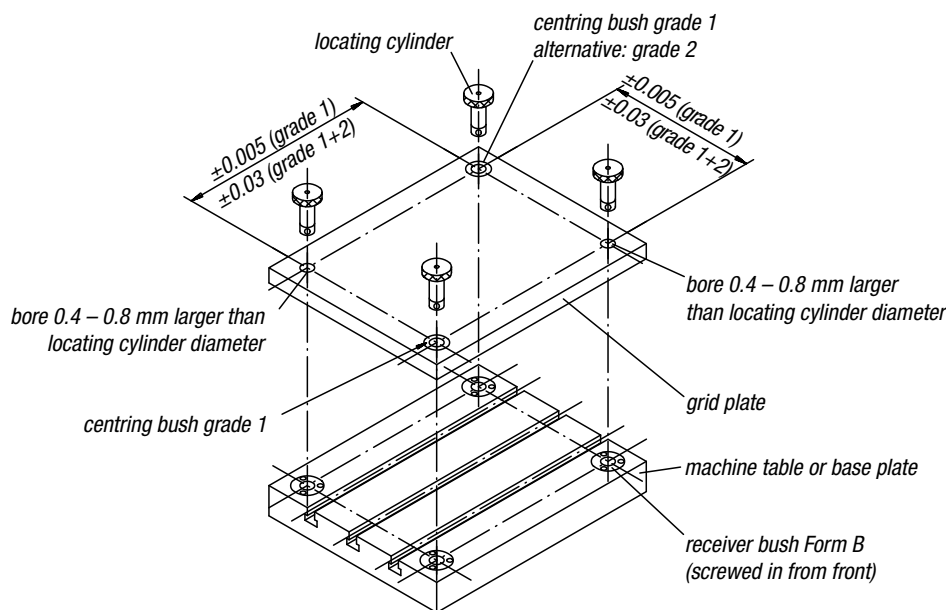
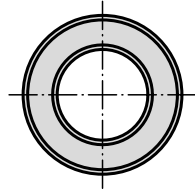
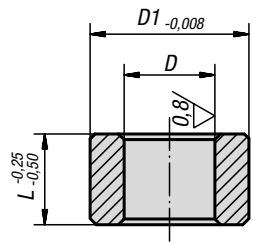

### KIPP Centring bushes

Order No. grade I	Order No. grade II	D	D1	L	Bore size for centring bush $\varnothing +0.01$
K0936.113013	K0936.213013	13*	19,04	13	19,016
K0936.113020	K0936.213020	13*	19,04	20	19,016
K0936.116020	K0936.216020	16*	25,042	20	25,016
K0936.116025	K0936.216025	16*	25,042	25	25,016
K0936.120020	K0936.220020	20*	35,042	20	35,018
K0936.120025	K0936.220025	20*	35,042	25	35,018
K0936.125020	K0936.225020	25*	35,042	20	35,018
K0936.125025	K0936.225025	25*	35,042	25	35,018
K0936.130020	K0936.230020	30*	45,042	20	45,018
K0936.130025	-	30*	45,042	25	45,018
K0936.135020	-	35*	45,042	20	45,018
K0936.135025	K0936.235025	35*	45,042	25	45,018
K0936.135040	K0936.235040	35*	45,042	40	45,018
K0936.135050	K0936.235050	35*	45,042	50	45,018
K0936.150020	-	50*	63,546	20	63,521
K0936.150040	K0936.250040	50*	63,546	40	63,521
K0936.150050	K0936.250050	50*	63,546	50	63,521
-	K0936.250025	50*	63,546	25	63,521

## Receiver bushes

Form A (pressed in from rear)

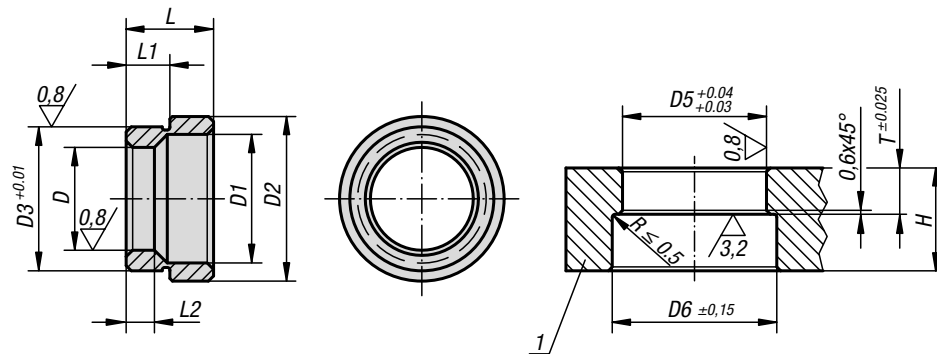

**Material:**  
Carbon steel.

**Version:**  
Tempered and black oxidised.

**Sample order:**  
K0937.20

**Drawing reference:**  
1) grid plate

### KIPP Receiver bushes Form A (pressed in from rear)

Order No.	D	D1	D2	D3	L	L1	L2	D5	D6	T	Min. grid plate thickness H
K0937.13	13	17,3	25	20,03	12,1	6,6	5,58	20	26	6,92	20
K0937.16	16	20,7	28,6	22,03	12,1	6,9	6,6	22	29	7,24	20
K0937.20	20	24,8	32,2	28,03	17,1	8,42	8,13	28	33	8,74	25
K0937.25	25	30,4	40,2	35,03	21	10,22	10,16	35	41	10,54	25
K0937.30	30	36,2	48,2	42,03	21,8	10,63	11,18	42	49	10,95	30
K0937.35	35	41,3	54,2	48,03	25,1	12,18	14,78	48	55	12,5	32
K0937.50	50	58,4	75,2	67,03	31,1	15,43	18,67	67	76	15,75	45

# K0938

## Receiver bushes

Form B (screwed down from front)

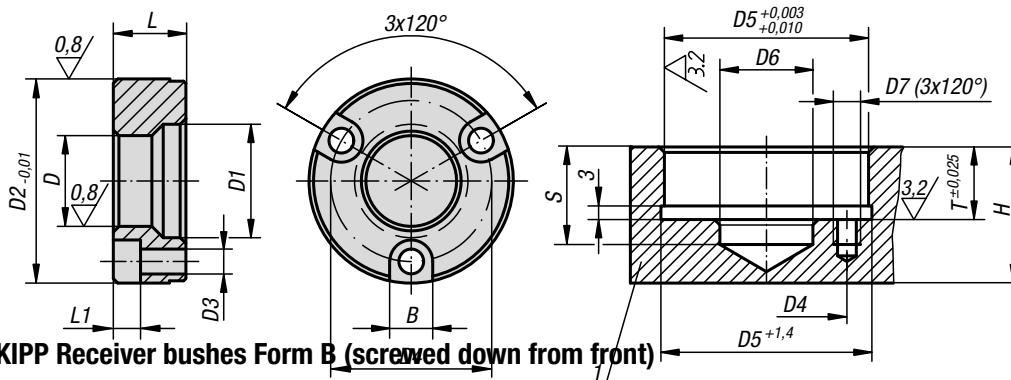

**Material:**  
Carbon steel.

**Version:**  
Tempered and black oxidised.

**Sample order:**  
K0938.13

**Note:**  
Fastening screws included.

**Drawing reference:**  
1) grid plate

### KIPP Receiver bushes Form B (screwed down from front)

Order No.	D	D1	D2	D3	D4	L	L1	B	D5	D6	D7	S	T	Min. grid plate thickness H
K0938.13	13	17,3	34,99	4,4	25	11,56	4,5	7,6	35	13,5	M4x7	20	11,91	20
K0938.16	16	20,7	36,99	4,4	29	11,56	4,5	7,6	37	21	M4x7	20	11,91	20
K0938.20	20	24,8	44,99	5,4	35	15,82	6	9,5	45	21	M5x9	25	16,21	25
K0938.25	25	30,4	54,99	6,4	42	19,94	7	11	55	25,5	M6x10	25	20,32	25
K0938.30	30	36,2	59,99	6,4	48	21,77	7	11	60	30,5	M6x11	30	22,15	30
K0938.35	35	41,3	69,99	8,4	56	22,61	9	14	70	40	M8x17	32	22,99	32
K0938.50	50	58,4	91,99	10,4	75	31,12	11	17	92	55	M10x18	45	31,5	45

# Pneumatic positioning and clamping system



## General information

1. The pneumatic positioning and clamping system enables rapid and precise fixation and positioning of grid plates. The system consists of a locating cylinder and a locating bush.
2. The locating cylinder is actuated pneumatically.
3. To use the positioning and clamping system, follow these three simple steps:  
Install two locating cylinders on the machine table or baseplate. At the same time install the locating bushes with the interchangeable subplates in line with the specified dimensions. Feed in air to open the locating cylinder mechanism to make the clamping balls move inwards. Insert the interchangeable subplate with the locating bushes and close the air valve again. The interchangeable subplate is now positioned and clamped.
4. The system is clamped without an air supply. Spring force is used for clamping in the locating cylinder. An air supply of 6 bar is required to open the mechanism.
5. 2 different installation variants are available.

### Example

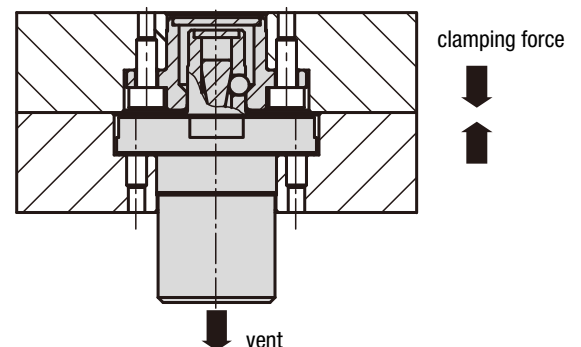
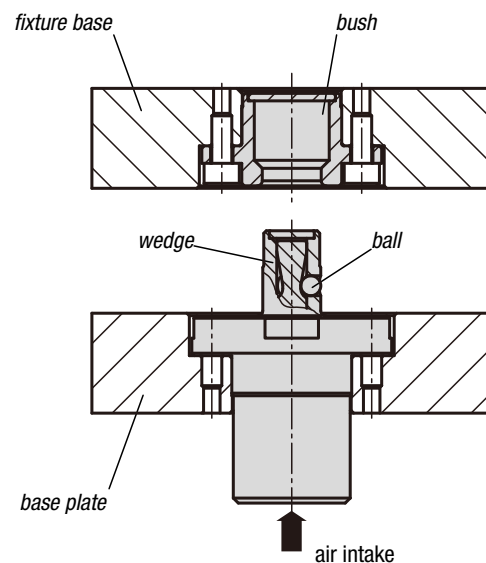
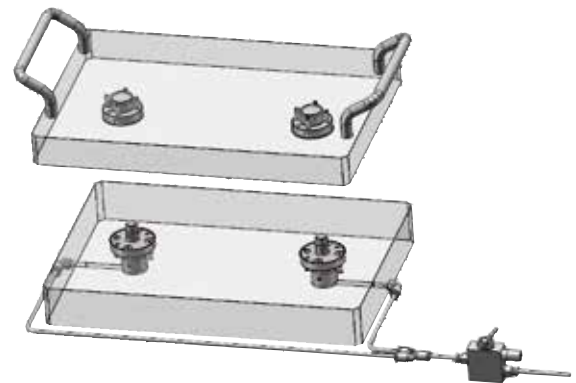

## Locating cylinders

pneumatic



**Material:**  
Carbon steel.

**Version:**  
nickel-plated.

**Sample order:**  
K1219.112

**Note:**  
The 3 clamping balls are pneumatically released. The 3 clamping balls retract and the fixture can be exchanged. If the air is stopped, the 3 clamping balls advance and the fixture is clamped. This easy-to-operate system significantly reduces the changeover times.

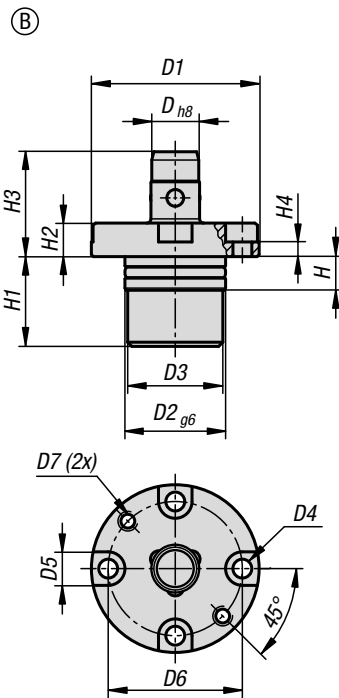
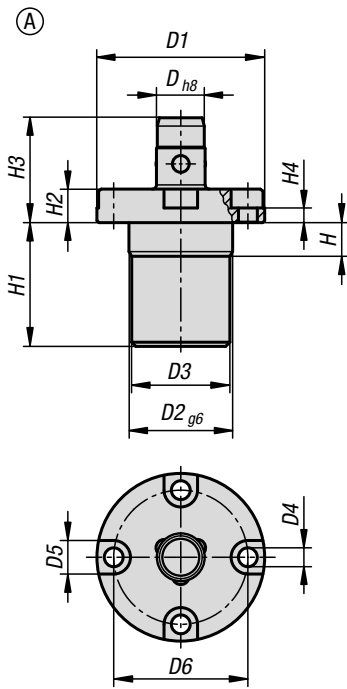

mounting instructions:

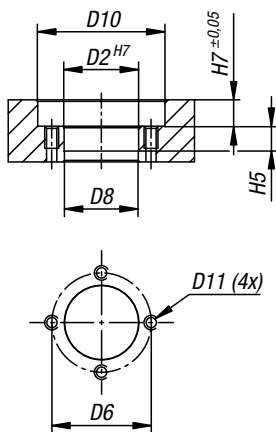

mounting instructions:

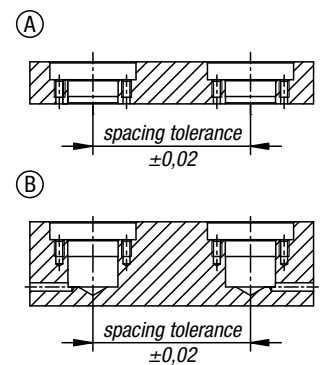
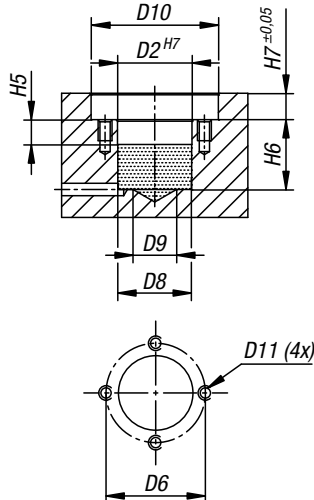

### KIPP Pneumatic locating cylinder

Order No.	Form	D	D1	D2	D3	D4	D5	D6	D7	D8	D9	D10	D11	H	H2	H1	H3	H4	H5	H6	H7	Retaining force F1 N
K1219.112	A	12	40	24	23,4	4,5	8	32	-	23,8	-	41	M4	8	8	29,5	25	3,5	8,5	-	8,5	250
K1219.116	A	16	51	32	31,4	5,5	9,5	41	-	31,8	-	52	M5	8,5	9,5	31,7	28,5	4	9	-	10	350
K1219.212	B	12	40	24	23,4	4,5	8	32	M4	23,8	14	41	M4	8	8	24,5	25	3,5	8,5	25,5	8,5	250
K1219.216	B	16	51	32	31,4	5,5	9,5	41	M5	31,8	20	52	M5	8,5	9,5	25,5	28,5	4	9	26,5	10	350

## Locating bushes

for pneumatic locating cylinder

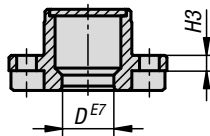
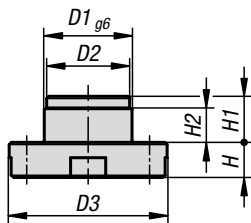
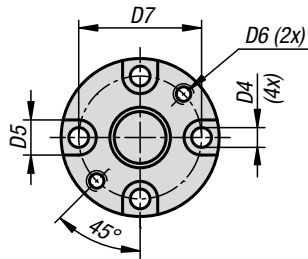

mounting instructions:

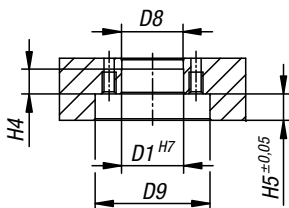
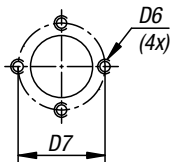

**Material:**

Carbon steel.

**Version:**

nickel-plated.

**Sample order:**

K1220.12

**Note:**

Locating bushes are placed in fixture or interchangeable subplates and form the counterpart to the locating cylinder.

The locating bushes are centred in a reamed hole and then fastened with 4 screws.

The balls of the locating cylinder engage in the groove in the locating bush, thereby forming a fast, secure and highly accurate changeover unit, and reducing setup and changeover times.

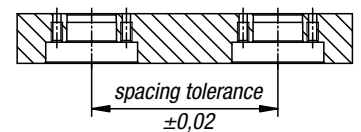

**KIPP Locating bush for pneumatic locating cylinder**

Order No.	D	D1	D2	D3	D4	D5	D6	D7	D8	D9	H	H1	H2	H3	H4	H5
K1220.12	12,1	20	19,6	36	4,5	8	M4	28	19,8	37	8	10,5	7,5	3,5	8	8,5
K1220.16	16,1	25	24,6	44	5,5	9,5	M5	34	24,8	45	9,5	11	7	4	7,5	10





The standard terms and conditions of sale, delivery and payment that you can find on our website [www.kipp.com](http://www.kipp.com) apply.

**HEINRICH KIPP WERK KG**  
Heubergstraße 2  
72172 Sulz am Neckar  
GERMANY

Tel.: +49 7454 793-0  
Fax: +49 7454 793-33  
E-Mail: [verkauf@kipp.com](mailto:verkauf@kipp.com)  
[technik@kipp.com](mailto:technik@kipp.com)  
Internet: [www.kipp.com](http://www.kipp.com)

**HEINRICH KIPP WERK KG**

Heubergstraße 2

72172 Sulz am Neckar

GERMANY

Tel. +49 7454 793-0

Fax +49 7454 793-7982

[info@kipp.com](mailto:info@kipp.com)

[www.kipp.com](http://www.kipp.com)

