

Tombstones window frame

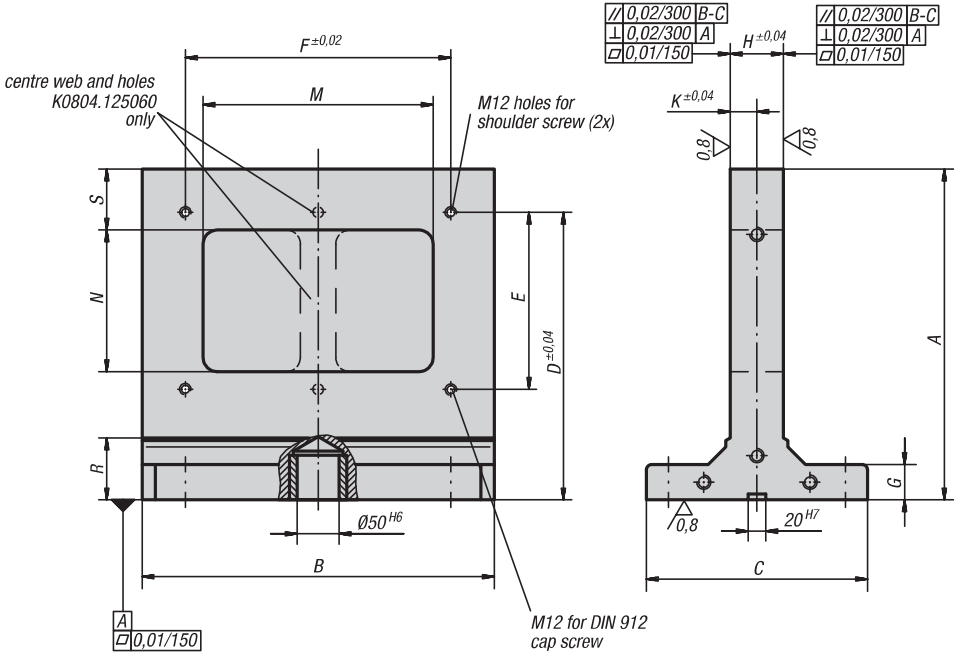
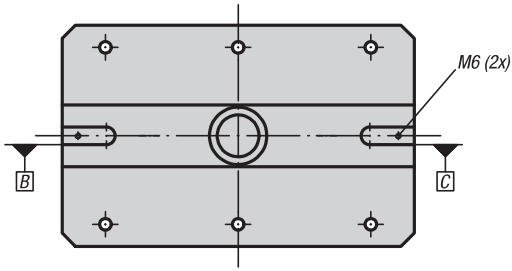

Material:
GJL 300

Version:
Reference surfaces precision machined

Sample order:
K0804.123040

Note:
Tooling plates K0801 can be positioned and mounted on both sides of the window frame, permitting economical fixture changes. The window frames are positioned using centring pins K0856 and slot guide nuts.

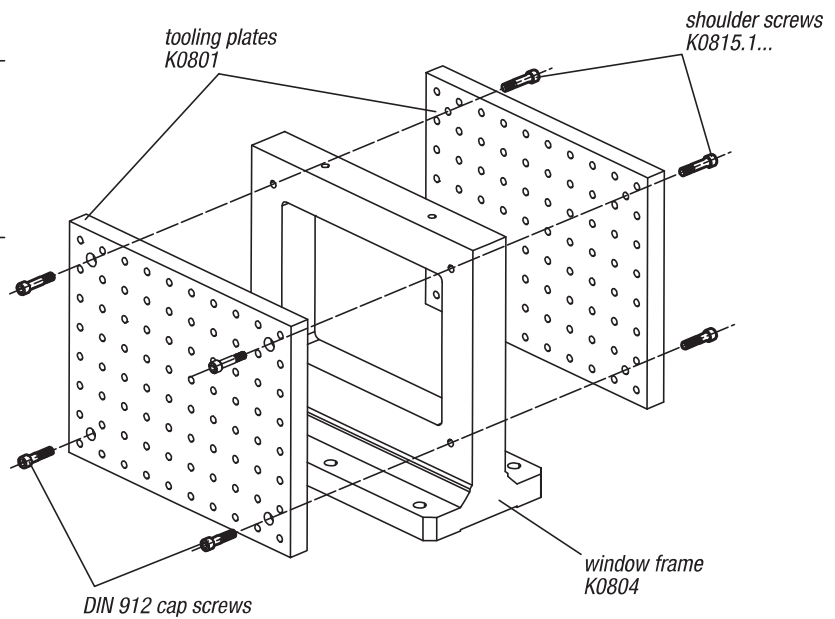
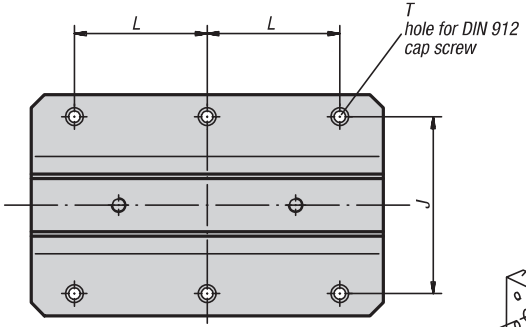

KIPP Tombstone window frame

Order No.	A	B	C	D	E	F	G	H	J	K	L	M	N	R	S	T	weight ca. kg
K0804.123040	374	398	250	325	200	300	40	60	200	30	150	260	160	70	69	M12	62
K0804.124050	474	498	250	425	300	400	40	70	200	35	200	360	260	70	69	M12	112.6
K0804.125060	574	598	300	525	400	500	50	70	200	35	200	458	360	75	70	M16	153