

Locating and clamping systems

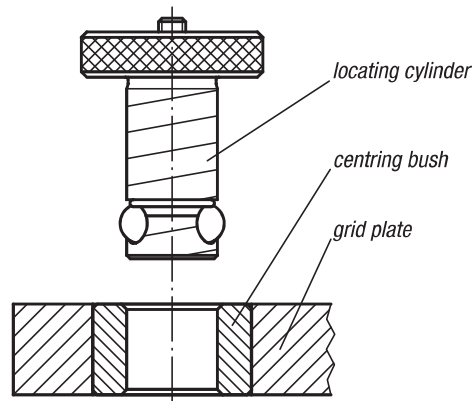

Locating and clamping system, mechanical



recommended installation

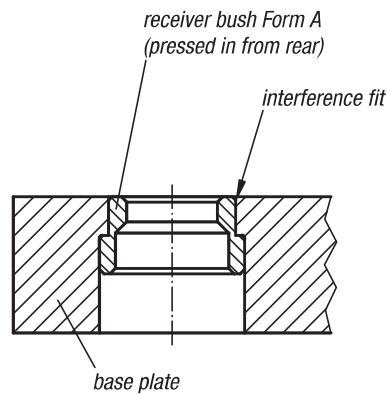

alternative installation

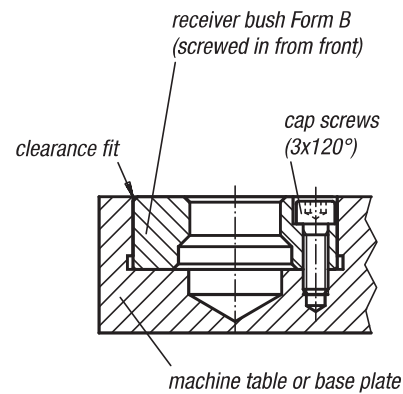

General information

1. With the mechanical locating and clamping system, base and tooling plates can be precisely positioned and fastening in a couple of seconds. The system consists of a locating cylinder, a centring bush and a receiver bush.
2. Three easy steps for using the positioning and clamping system:
 Mount two receiver bushes on the machine table or base plate, and two centring bushes in the clamping plate.
 Insert the locating cylinder through the centring bush into the receiver bush to attain precise positioning.
 Turn the set screws in each locating cylinder roughly two rotations for tight clamping.
 Eighteen different locating cylinders, two centring bush types and two receiver bush forms are available.
3. A centring bush grade I (below left) and a centring bush grade I or II (above right) should be installed in each fastening plate as far apart from one another as possible. More than two positioning points bring no further advantages.
 When more than two locating cylinders are used for additional holding force (dependent on application), holes in the fastening plate must be 0.4 mm to 0.8 mm bigger than the selected locating cylinder diameter.
4. If the centre distance between the two positioning holes in the e.g. machine table and the clamping plate is kept within a tolerance of ± 0.005 mm and two centring bushings grade I are used, a repeat accuracy within ± 0.013 mm can be achieved.
 For a somewhat lower repeat accuracy within ± 0.04 mm, one centring bushing grade I and one centring bushing grade II with a centre distance tolerance of ± 0.03 mm are used.
5. The difference between the centring bush grade I and the centring bush grade II is that the centring bush grade II has a larger internal diameter in order to correspond to the greater centre distance tolerance in the machine table or the base plate.

Locating cylinders

Ball Lock

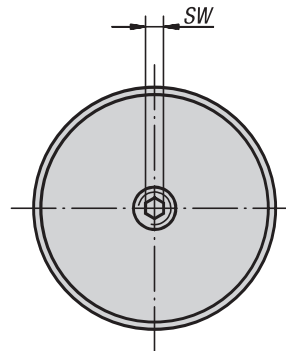
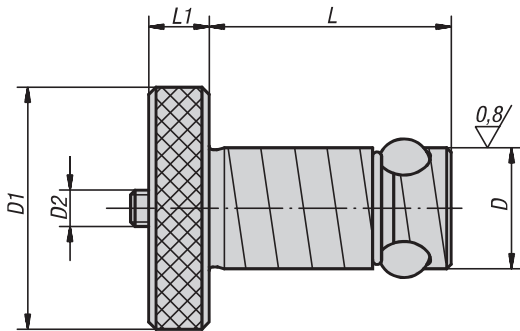

Material:

Locating cylinder carbon steel.
Balls roller bearing steel.

Version:

Locating cylinder tempered, black oxidised.
Balls hardened, bright.

Sample order:

K0935.16020

Note:

By tightening the thrust screw (D2) the centre ball is pressed downwards and in turn forces the three locking balls outwards, where they locked in the receiver bush.

With this easy to use system machine set-up times are up to twelve times shorter than when conventional methods are used.



KIPP Locating cylinders Ball lock

Order No.	Grid plate thickness $\pm 0,05$	D	D1	D2	L	L1	SW	Holding force F kN	Tightening torque max. Nm	Order No. Repair Kit
K0935.13013	13	13	22	M5	27,6	6	2,5	3,3	1	K0935.913013
K0935.13020	20	13	22	M5	34,6	6	2,5	3,3	1	K0935.913020
K0935.16020	20	16	32	M6	36,5	8	3	5,3	3	K0935.916020
K0935.16025	25	16	32	M6	41,5	8	3	5,3	3	K0935.916025
K0935.20020	20	20	40	M6	39,5	10	3	13,3	4	K0935.920020
K0935.20025	25	20	40	M6	44,5	10	3	13,3	4	K0935.920025
K0935.25020	20	25	45	M8	44	10	4	30	9	K0935.925020
K0935.25025	25	25	45	M8	49	10	4	30	9	K0935.925025
K0935.30020	20	30	50	M10	49	13	5	44	15	K0935.930020
K0935.30025	25	30	50	M10	54	13	5	44	15	K0935.930025
K0935.35020	20	35	60	M12	51	13	6	68	25	K0935.935020
K0935.35025	25	35	60	M12	56	13	6	68	25	K0935.935025
K0935.35040	40	35	60	M12	71	13	6	68	25	K0935.935040
K0935.35050	50	35	60	M12	81	13	6	68	25	K0935.935050
K0935.50020	20	50	75	M20	64	20	10	88	50	K0935.950020
K0935.50025	25	50	75	M20	69	20	10	88	50	K0935.950025
K0935.50040	40	50	75	M20	84	20	10	88	50	K0935.950040
K0935.50050	50	50	75	M20	94	20	10	88	50	K0935.950050

Locating cylinder

with quick clamping system

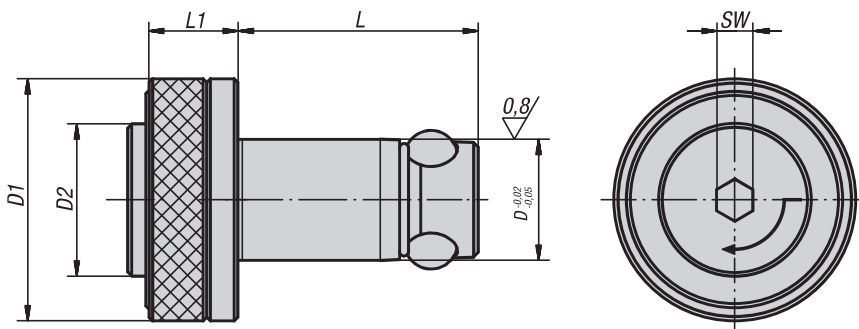

Material:

Locating cylinder carbon steel.
Balls roller bearing steel.

Version:

Locating cylinder tempered, black oxidised.
Balls hardened, bright.

Sample order:

K0935.112013

Note:

Locating cylinder with quick-clamp system for extra timesaving during setups.

Insert the locating cylinder into the receiving hole and press the button. The three balls are pushed out and position the components. By tightening the set screw a 1/4 turn using an hexagonal key, the components are positively and securely held.



KIPP Locating cylinder with quick clamping system

Order No.	Grid plate thickness $\pm 0,05$	D	D1	D2	L	L1	SW	Holding force F kN	Tightening torque max. Nm
K0935.113020	20	13	25	16	34,6	12	4	4	1
K0935.116020	20	16	32	20	36,5	15	6	8	2
K0935.120020	20	20	40	25	39,5	15	6	8	2
K0935.120025	25	20	40	25	44,5	15	6	8	2
K0935.116025	25	16	32	20	41,5	15	6	8	2
K0935.113013	13	13	25	16	27,6	12	4	4	1

Centring bushes



Material:
Ball bearing steel

Version:
Hardened, black oxidised.

Sample order:
K0936.113020

Note:
By a centre distance tolerance of ± 0.005 mm and two grade I centring bushes a repeat accuracy of ± 0.013 mm is possible.
By a centre distance tolerance of ± 0.03 mm and one grade I centring bush and one grade II centring bush repeat accuracy of ± 0.04 mm is possible.
The centring bush is pressed with light pressure into the receiver holes in tooling plates.
For further details see „General information“.

* Tol. for grade I centring bushes $+0.005 / +0.018$
Tol. for grade II centring bushes $+0.025 / +0.050$

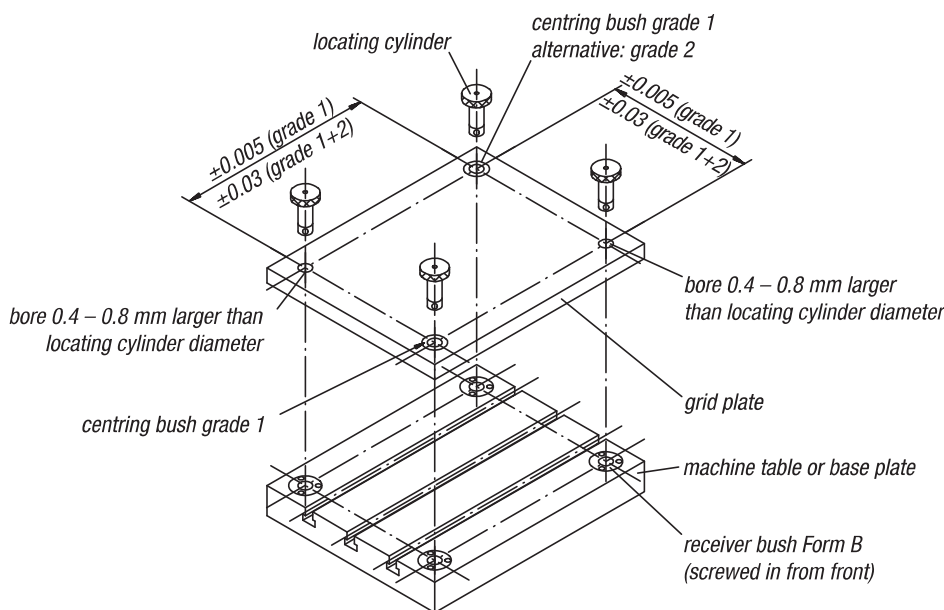
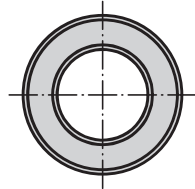
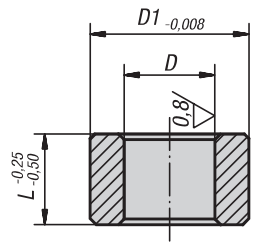

KIPP Centring bushes

Order No. grade I	Order No. grade II	D	D1	L	Bore size for centring bush $\varnothing +0.01$
K0936.113013	K0936.213013	13*	19,04	13	19,016
K0936.113020	K0936.213020	13*	19,04	20	19,016
K0936.116020	K0936.216020	16*	25,042	20	25,016
K0936.116025	K0936.216025	16*	25,042	25	25,016
K0936.120020	K0936.220020	20*	35,042	20	35,018
K0936.120025	K0936.220025	20*	35,042	25	35,018
K0936.125020	K0936.225020	25*	35,042	20	35,018
K0936.125025	K0936.225025	25*	35,042	25	35,018
K0936.130020	K0936.230020	30*	45,042	20	45,018
K0936.130025	-	30*	45,042	25	45,018
K0936.135020	-	35*	45,042	20	45,018
K0936.135025	K0936.235025	35*	45,042	25	45,018
K0936.135040	K0936.235040	35*	45,042	40	45,018
K0936.135050	K0936.235050	35*	45,042	50	45,018
K0936.150020	-	50*	63,546	20	63,521
K0936.150040	K0936.250040	50*	63,546	40	63,521
K0936.150050	K0936.250050	50*	63,546	50	63,521
-	K0936.250025	50*	63,546	25	63,521



Receiver bushes

Form A (pressed in from rear)

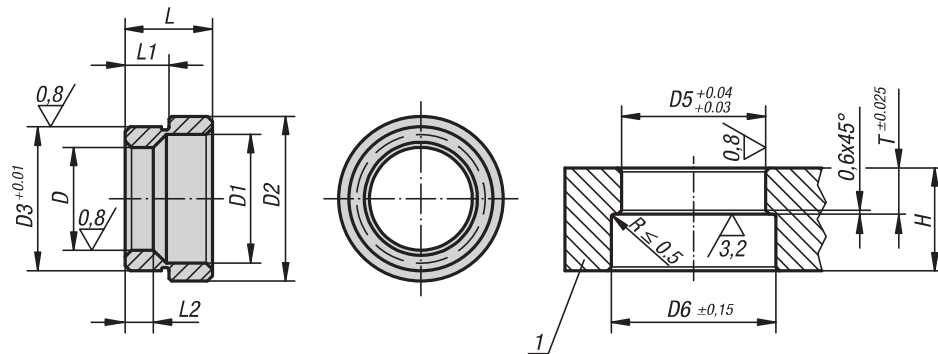

Material:
Carbon steel.

Version:
Tempered and black oxidised.

Sample order:
K0937.20

Drawing reference:
1) grid plate

KIPP Receiver bushes Form A (pressed in from rear)

Order No.	D	D1	D2	D3	L	L1	L2	D5	D6	T	Min. grid plate thickness H
K0937.13	13	17,3	25	20,03	12,1	6,6	5,58	20	26	6,92	20
K0937.16	16	20,7	28,6	22,03	12,1	6,9	6,6	22	29	7,24	20
K0937.20	20	24,8	32,2	28,03	17,1	8,42	8,13	28	33	8,74	25
K0937.25	25	30,4	40,2	35,03	21	10,22	10,16	35	41	10,54	25
K0937.30	30	36,2	48,2	42,03	21,8	10,63	11,18	42	49	10,95	30
K0937.35	35	41,3	54,2	48,03	25,1	12,18	14,78	48	55	12,5	32
K0937.50	50	58,4	75,2	67,03	31,1	15,43	18,67	67	76	15,75	45

Receiver bushes

Form B (screwed down from front)

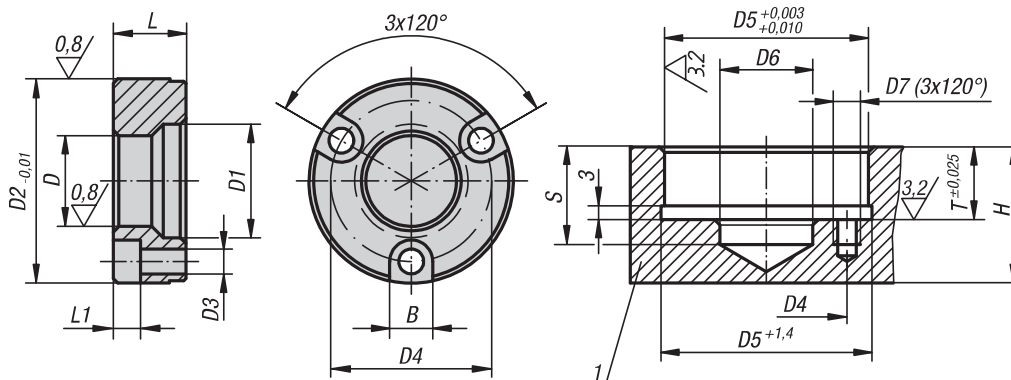

Material:
Carbon steel.

Version:
Tempered and black oxidised.

Sample order:
K0938.13

Note:
Fastening screws included.

Drawing reference:
1) grid plate

KIPP Receiver bushes Form B (screwed down from front)

Order No.	D	D1	D2	D3	D4	L	L1	B	D5	D6	D7	S	T	Min. grid plate thickness H
K0938.13	13	17,3	34,99	4,4	25	11,56	4,5	7,6	35	13,5	M4x7	20	11,91	20
K0938.16	16	20,7	36,99	4,4	29	11,56	4,5	7,6	37	21	M4x7	20	11,91	20
K0938.20	20	24,8	44,99	5,4	35	15,82	6	9,5	45	21	M5x9	25	16,21	25
K0938.25	25	30,4	54,99	6,4	42	19,94	7	11	55	25,5	M6x10	25	20,32	25
K0938.30	30	36,2	59,99	6,4	48	21,77	7	11	60	30,5	M6x11	30	22,15	30
K0938.35	35	41,3	69,99	8,4	56	22,61	9	14	70	40	M8x17	32	22,99	32
K0938.50	50	58,4	91,99	10,4	75	31,12	11	17	92	55	M10x18	45	31,5	45

Pneumatic positioning and clamping system



General information

1. The pneumatic positioning and clamping system makes it possible to precisely fix and position grid plates and baseplates in seconds. The system consists of a locating cylinder and a locating bush.
2. The locating cylinder is actuated pneumatically.
3. To use the positioning and clamping system, follow these three simple steps: Install two locating cylinders in the machine table or baseplate. Also install the locating bushes with the interchangeable subplates in line with the specified dimensions. Feed in air to open the locating cylinder mechanism. This makes the clamping balls travel inwards. Insert the interchangeable subplate with the locating bushes and close the air valve again. The interchangeable subplate is now positioned and clamped.
4. The system is clamped without an air supply. Spring force is used for clamping in the locating cylinder. An air supply of 6 bar is required to open the mechanism.
5. 2 different installation variants are available.

Example

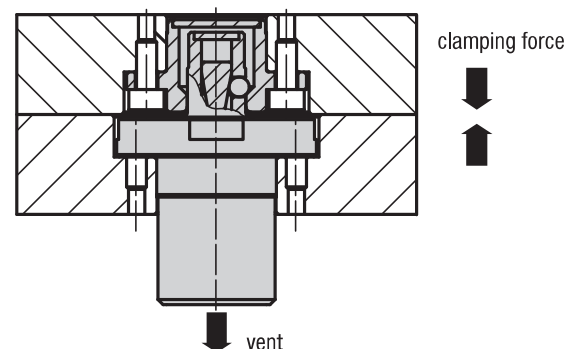
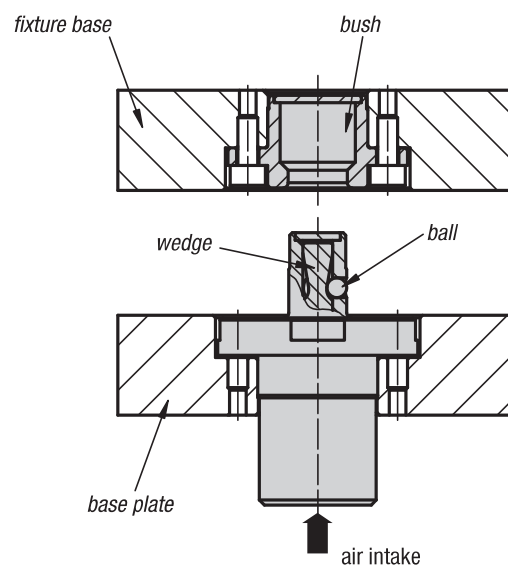
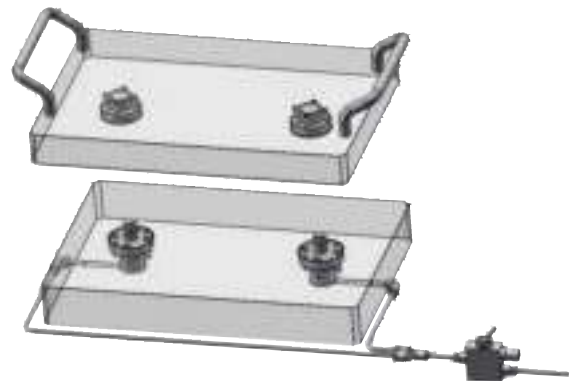

Locating cylinders

pneumatic

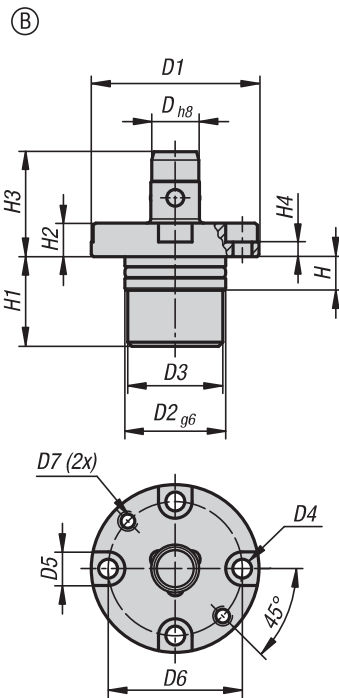
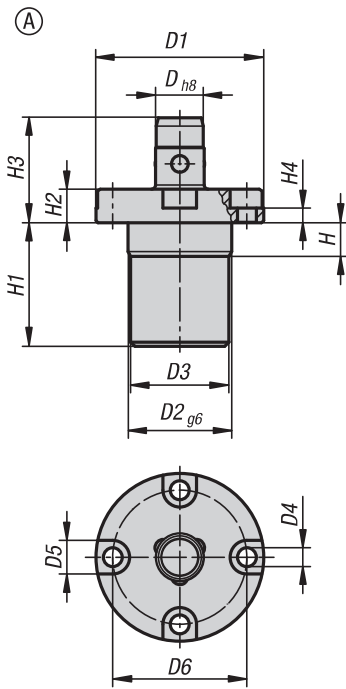

Material:

Carbon steel.

Version:

nickel-plated.

Sample order:

K1219.112

Note:

The 3 clamping balls are pneumatically released. The 3 clamping balls retract and the fixture can be exchanged. If the air is stopped, the 3 clamping balls advance and the fixture is clamped. This easy-to-operate system significantly reduces the changeover times.

mounting instructions:

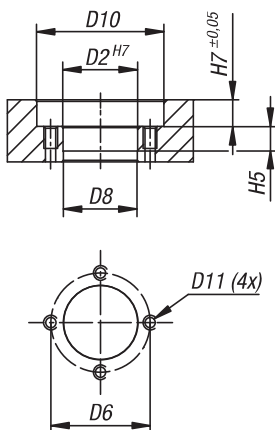

mounting instructions:

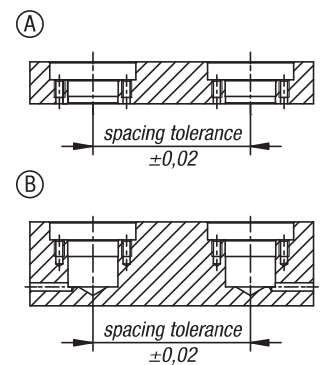
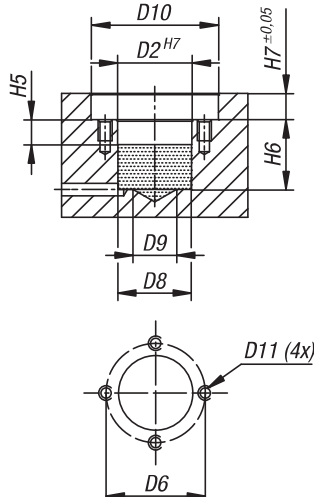

KIPP Pneumatic locating cylinder

Order No.	Form	D	D1	D2	D3	D4	D5	D6	D7	D8	D9	D10	D11	H	H2	H1	H3	H4	H5	H6	H7	Retaining force F1 N
K1219.112	A	12	40	24	23,4	4,5	8	32	-	23,8	-	41	M4	8	8	29,5	25	3,5	8,5	-	8,5	250
K1219.116	A	16	51	32	31,4	5,5	9,5	41	-	31,8	-	52	M5	8,5	9,5	31,7	28,5	4	9	-	10	350
K1219.212	B	12	40	24	23,4	4,5	8	32	M4	23,8	14	41	M4	8	8	24,5	25	3,5	8,5	25,5	8,5	250
K1219.216	B	16	51	32	31,4	5,5	9,5	41	M5	31,8	20	52	M5	8,5	9,5	25,5	28,5	4	9	26,5	10	350

Locating bushes

for pneumatic locating cylinder



Material:
Carbon steel.

Version:
nickel-plated.

Sample order:
K1220.12

Note:
Locating bushes are placed in fixture or interchangeable subplates and form the counterpart to the locating cylinder.
The locating bushes are centred in a reamed hole and then fastened with 4 screws.
The balls of the locating cylinder engage in the groove in the locating bush, thereby forming a fast, secure and highly accurate changeover unit, and reducing setup and changeover times.

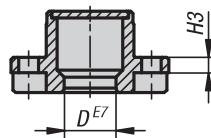
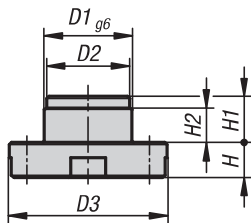
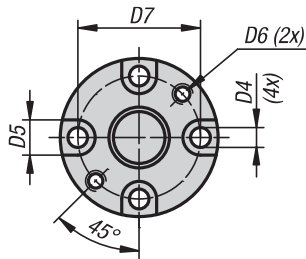

mounting instructions:

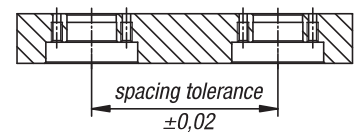
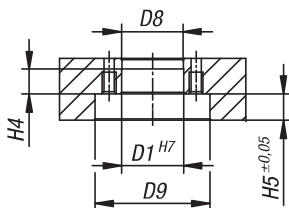
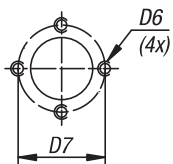

KIPP Locating bush for pneumatic locating cylinder

Order No.	D	D1	D2	D3	D4	D5	D6	D7	D8	D9	H	H1	H2	H3	H4	H5
K1220.12	12,1	20	19,6	36	4,5	8	M4	28	19,8	37	8	10,5	7,5	3,5	8	8,5
K1220.16	16,1	25	24,6	44	5,5	9,5	M5	34	24,8	45	9,5	11	7	4	7,5	10