



JAP200 Rotary Air Collet Chuck



- ▲ Built in rotary cylinder, free from draw bar and rotary cylinder
- ▲ Easy installation, no specialist required
- ▲ Work with most popular collet , easy to find replacement or repair in local.
- ▲ Double piston, provide more clamping force in limited O.D
- ▲ Import selected deep groove ball bearing, stable and tough
- ▲ Self-lock design on the close side to offer higher safety
- ▲ High resistance to coolant fluid and cutting chips
(Fluid and dust proof when air feeding in)
- ▲ Please use 5um filter in F.R.L units

Introduction

JAP200 is built in rotary cylinder, which is free from use the draw bar and rotary cylinder behind the spindle. Even makes it much easier. All you need is a flange adaptor and air feeding, imaging a simple installation without specialist worker and anyone with technical common sense, can get installation done easily when all relates components ready.

JAP200 air collet chuck is a high performance chuck, applies to all kind of automation lathe working .Also can works with manual lathe to fulfill the target of auto clamping. Center trough hole allowed feeding either way from the front or rear, or to make an axial stopper in the center, or set an air blower to clear to cutting chips.

Collet provides the higher frequency to clamp, compare to 3-jaws chuck, collet chuck is up to save the time of clamping more than 75%. Any manufacturer whoever is paying attention to the cycle time, collet chuck is able to raise your output when you have the same time putting in.



Applies: On Lathe

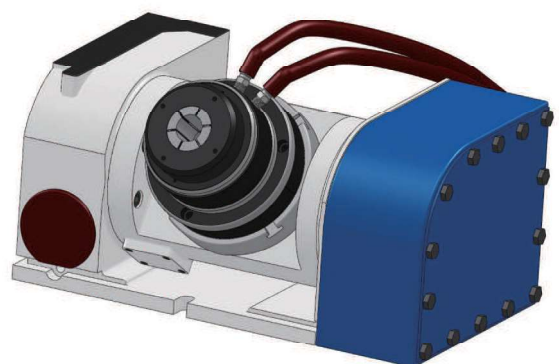

Applies: On 4/5 axis rotary table

Rotary Air Collet Chuck

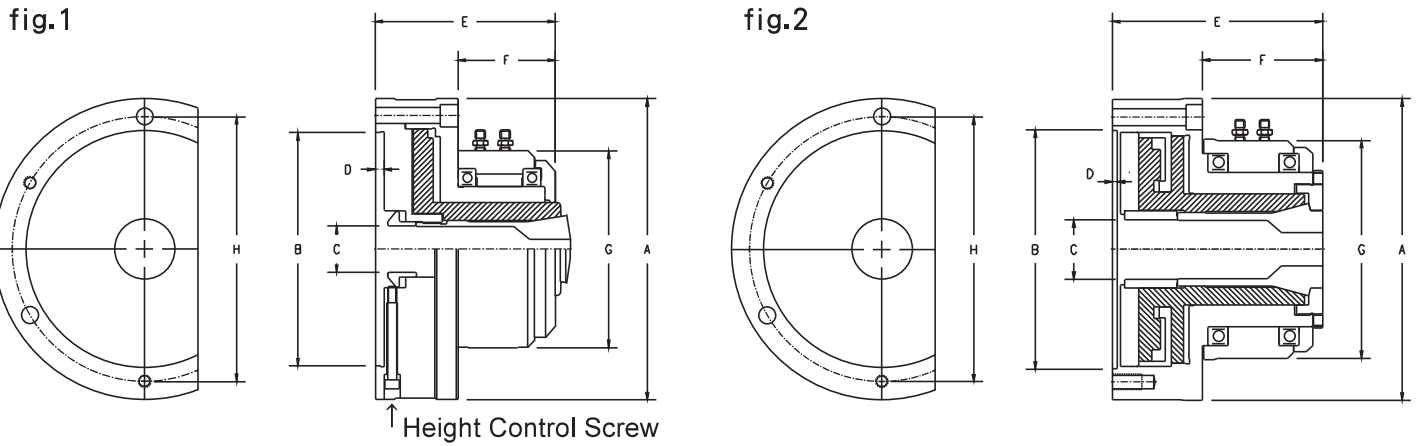

JAP200 Dimension and Specification

Model	JAP206-5C	JAP207-16C	JAP207-B42	JAP208-B60	JAP210-B80
Figure	fig.1	fig.1	fig.2	fig.2	fig.2
A	168(6.61")	203(7.99")	197(7.76")	214(8.43")	247(9.72")
B	130(5.12")	160(6.30")	155(6.10")	170(6.69")	200(7.87")
C	26(1.02")	40(1.57")	42(1.65")	60(2.36")	80(3.15")
D	4.5(0.18")	4.5(0.18")	4.5(0.18")	4.5(0.18")	5.0(0.20")
E	101(3.98")	113(4.44")	138(5.43")	148(5.83")	151(5.94")
F	55(2.17")	65(2.56")	77(3.03")	85(3.35")	80(3.16")
G	116(4.57")	136(5.35")	146(5.76")	164(6.46")	197(7.76")
H (P.C.D.)	147(5.79")	176(6.93")	172(6.77")	186(7.32")	226(8.90")
Mounting Bolts	4H-M8 (front)	3H-M10 (front)+ 3H-M10 (rear)	3H-M 10(front)+ 3H-M 10(rear)	3H-M10 (front)+ 3H-M10 (rear)	6H-M10 (front)
Collet	5C Collet	16C Collet	B42(DIN6343 173E)	B60(DIN6343 185E)	B80(DIN6343 193E)
Max. RPM	3600	2800	2500	2000	1500
Air Pressure	3-8kg/cm ² (43-114psi)	3-8kg/cm ² (43-114psi)	3-8kg/cm ² (43-114psi)	3-8kg/cm ² (43-114psi)	3-8kg/cm ² (43-114psi)
Max. Capacity	26mm(1.02")	40mm(1.57")	42mm(1.65")	60mm(2.36")	80mm(3.15")
Piston Area	130cm ² (20.2in ²)	155cm ² (24.0in ²)	280cm ² (43.4in ²)	304cm ² (47.6in ²)	356cm ² (55.2in ²)
Gripping Force	3465kgf@7kg/cm ² (7623lbf@100psi)	4078kgf@7kg/cm ² (8971lbf@100psi)	4740kgf@7kg/cm ² (10428lbf@100psi)	5150kgf@7kg/cm ² (11330lbf@100psi)	6030kgf@7kg/cm ² (12060lbf@100psi)
Net Weight	10kgs(22lbs)	14kgs(31lbs)	17kgs(37lbs)	21kgs(46lbs)	32kgs(71lbs)