

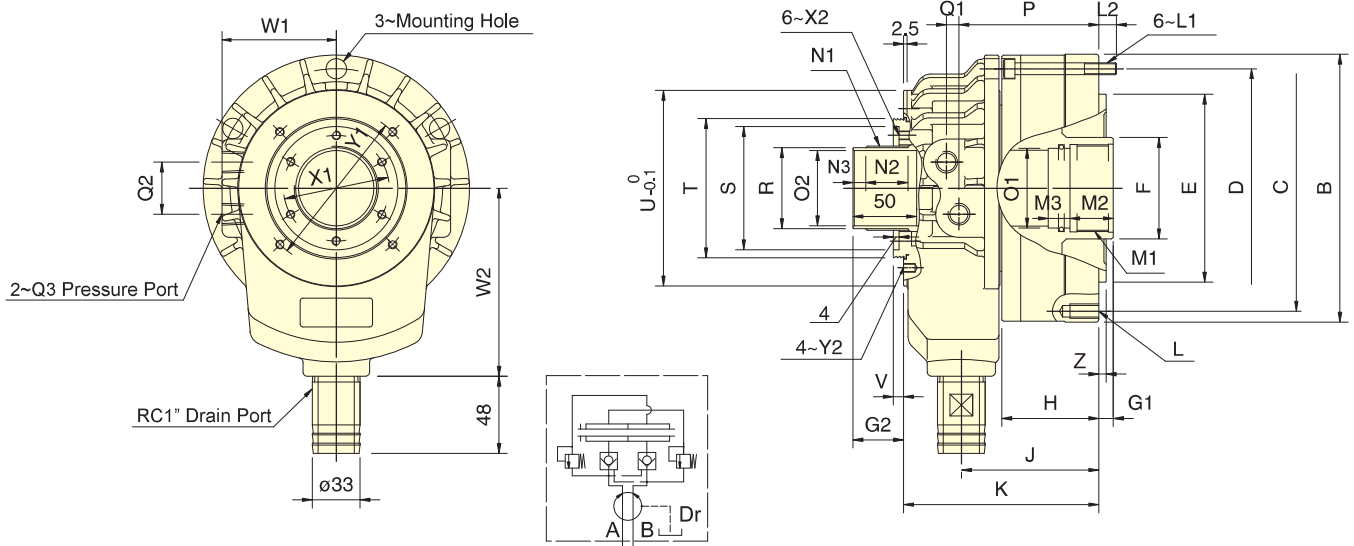

- Super short form, light weight large Through-Hole, just as 2/3 of typical model length.
- Built-in safety check valves and pressure relief valves.
- Can screw it from the rear end of the cylinder when mounting.
- Patent numbers :
Taiwan : PAT.NO.M491534
China : PAT.NO.ZL201420584274.5



Subject to technical changes

SPECIFICATIONS

Model	Eff. piston area		Piston stroke mm	Max. speed min ⁻¹ (r.p.m.)	Max. pressure MPa(kgf/cm ²)	I Moment of inertia kg·m ²	Weight kg	Total oil leakage lit. / min.
	Extend cm ²	Retract cm ²						
TK-A528	73.0	69.7	12	8000	4.5 (45)	0.012	6.2	3.0
TK-A533	73.0	69.7	12	8000	4.5 (45)	0.012	6.0	3.0
TK-C643	99.1	88.0	15	7000	4.5 (45)	0.018	7.5	3.0
TK-A646	105.0	93.9	15	7000	4.5 (45)	0.018	7.3	3.0
TK-B646	105.0	93.9	15	7000	4.5 (45)	0.018	8.6	3.0
TK-C646	99.1	88.0	15	7000	4.5 (45)	0.018	7.5	3.0
TK-B846	135.3	125.0	20	6300	4.5 (45)	0.032	12.4	3.9
TK-A853	135.3	125.0	20	6300	4.5 (45)	0.032	11.8	3.9
TK-B853	135.3	125.0	20	6300	4.5(45)	0.032	11.7	3.9
TK-1068	165.9	149.9	25	5500	4.5 (45)	0.065	17.8	4.2
TK-A1075	170.0	155.0	25	5500	4.5(45)	0.065	18.8	4.2
TK-A1078	170.1	155.3	25	5500	4.5 (45)	0.065	17.4	4.2

DIMENSIONS

Model	A	B	C	D	E	F	G1		G2		H	J	K	L	L1	L2	M1	M2	M3
	I.D.				h7		max.	min.	max.	min.									
TK-A528	105	141	125	125	110	45	12	0	38	26	49	77.5	123	6~M8x20	M8x55	14	M38x1.5	25	13
TK-A533	105	141	125	125	110	45	12	0	38	26	49	77.5	123	6~M10x20	M8x55	14	M38x1.5	25	13
TK-C643	128	156	140	140	120	65	15	0	44	29	56	85	125	12~M10x20	M8x60	12	M50x2	25	13
TK-A646	128	162	147	147	130	65	15	0	44	29	56	85	125	12~M10x20	M8x60	12	M55x2	25	13
TK-B646	128	162	130	147	100	65	15	0	44	29	66	95	135	12~M10x20	M8x70	12	M55x2	25	13
TK-C646	125	156	140	140	120	65	15	0	44	29	56	85	125	12~M10x20	M8x60	12	M55x2	25	13
TK-B846	145	185	170	165	130	70	20	0	48	28	66	95	135	12~M10x20	M8x70	12	M55x2	30	15
TK-A853	145	185	170	165	140	70	20	0	48	28	66	95	135	12~M10x20	M8x70	12	M60x2	30	15
TK-B853	145	185	170	165	130	70	20	0	48	28	66	95	135	12~M10x20	M8x70	12	M60x2	30	15
TK-1068	170	212	190	190	160	98	25	0	50	25	73	107	157	12~M10x20	M10x80	17	M75x2	35	15
TK-A1075	170	212	190	190	160	95	25	0	50	25	74	108	158	M10x20	M10x80	16	M85x2	35	15
TK-A1078	170	212	190	190	160	95	25	0	50	25	74	108	158	12~M10x20	M10x80	16	M87x2	35	15

Model	N1	N2	N3	O1	O2	P	Q1	Q2	Q3	R	S	T	U	V	W1	W2	X1	X2	Y1	Y2	Z
				H8	H8					g7	H7										
TK-A528	M39x1.5	25	8	35	28	79	8.5	30	RC1/4	37	62	70	98	6	62	110	49	M6x6	83	M5x6	5
TK-A533	M39x1.5	25	8	35	33	79	8.5	30	RC1/4	37	62	70	98	6	62	110	49	M6x6	83	M5x6	5
TK-C643	M52x1.5	29	9	45	43	87	8.5	36	RC3/8	50	76	85	116	6	74	120	64	M6x6	98	M5x6	5
TK-A646	M52x1.5	29	9	50	46	87	8.5	36	RC3/8	50	76	85	116	6	74	120	64	M6x6	98	M5x6	5
TK-B646	M52x1.5	29	9	50	46	97	8.5	36	RC3/8	50	76	85	116	6	74	120	64	M6x6	98	M5x6	5
TK-C646	M52x1.5	29	9	50	46	87	8.5	36	RC3/8	50	76	85	116	6	74	120	64	M6x6	98	M5x6	5
TK-B846	M58x1.5	30	8	50	46	97	8.5	36	RC3/8	56	85	96	128	7	79	130	73	M6x7	110	M6x6	5
TK-A853	M58x1.5	30	8	55	53	97	8.5	36	RC3/8	56	85	96	128	7	79	130	73	M6x7	110	M6x6	5
TK-B853	M58x1.5	30	8	55	53	97	8.5	36	RC3/8	56	85	96	128	7	79	130	73	M6x7	110	M6x6	5
TK-1068	M84x2	33	9	70	68	109	12	40	RC1/2	81	108	121	164	7	98	160	98	M6x8	155	M6x8	5
TK-A1075	M84x2	33	9	80	75	110	12	40	RC1/2	81	108	121	164	7	98	160	98	M6x8	155	M6x8	5
TK-A1078	M84x2	33	9	82	78	110	12	40	RC1/2	81	108	121	164	7	98	160	98	M6x8	155	M6x8	5



- Super short form, light weight large Through-Hole, just as 2/3 of typical model length.
 - Built-in safety check valves and pressure relief valves.
 - Can screw it from the rear end of the cylinder when mounting.
- Patent numbers :
 Taiwan : PAT.NO.M491534
 China : PAT.NO.ZL201420584274.5

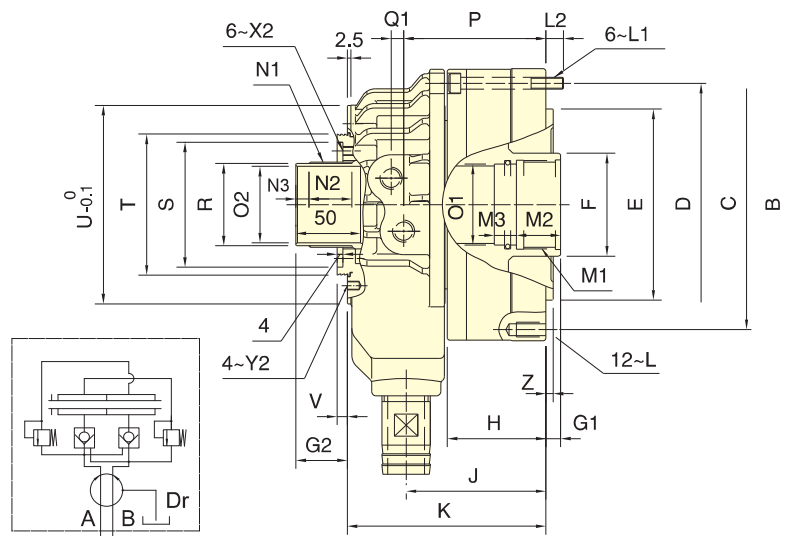
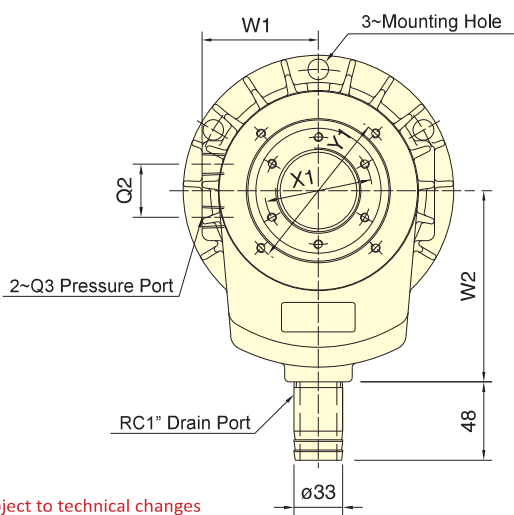

Subject to technical changes

SPECIFICATIONS

Model	Eff. piston area		Piston stroke	Max. speed	Max. pressure	I Moment of inertia	Weight	Total oil leakage
	Extend cm ²	Retract cm ²						
TK-A1287	234.0	217.5	30	3800	4.0 (40)	0.092	24.8	4.5
TK-A1291	234.0	217.5	30	3800	4.0 (40)	0.092	24.8	4.5
TK-A1511	336.4	315.2	30	3000	3.5(35)	0.38	57.9	7.0
TK-A1512	336.4	315.2	30	3000	3.5(35)	0.38	53.8	7.0
TK-2114	373.2	336.1	35	2500	3.0 (30)	0.54	58.2	8.0

DIMENSIONS

Model	A	B	C	D	E	F	G1		G2		H	J	K	L	L1	L2	M1	M2	M3
	I.D.				h7		max.	min.	max.	min.									
TK-A1287	200	245	215	225	180	110	30	0	59	29	86	126	184	12~M12x24	M10x90	14.5	M95x2	35	15
TK-A1291	200	245	215	225	180	110	30	0	59	29	86	126	184	12~M12x24	M10x90	14.5	M100x2	35	15
TK-A1511	250	300	275	275	230	140	30	0	58	28	102	156	226	12~M16x36	M12x110	21	M120x2	45	15
TK-A1512	250	300	275	275	230	140	30	0	58	28	102	156	226	12~M16x36	M12x110	21	M130x2	45	15
TK-2114	265	320	295	295	240	165	35	0	60	25	115	173.5	247.5	12~M16x32	M12x120	17.5	M155x2	45	20

Model	N1	N2	N3	O1	O2	P	Q1	Q2	Q3	R	S	T	U	V	W1	W2	X1	X2	Y1	Y2	Z
				H8	H8					g7	H7										
TK-A1287	M99x2	38	9	90	87	127.5	15	45	RC1/2	96	120	138	180	7	110	185	108	M6x10	165	M6x10	5
TK-A1291	M99x2	38	9	95	91	127.5	15	45	RC1/2	96	120	138	180	7	110	185	108	M6x10	165	M6x10	5
TK-A1511	M129x2	38	9	115	110	153.75	17	50	RC1/2	126	150	170	227	7	134	210	138	M6x10	210	M6x9	6
TK-A1512	M129x2	38	9	125	120	153.75	17	50	RC1/2	126	150	170	227	7	134	210	138	M6x10	210	M6x9	6
TK-2114	M149x2	38	9	145	140	170	17	50	RC1/2	146	170	190	250	7	145	210	160	M6x10	230	M6x10	6



- New design, short form, light weight large through-hole.
- Built-in safety check valves and pressure relief valves.
- Patent numbers :
Taiwan : PAT.NO.M491534
China : PAT.NO.ZL201420584274.5

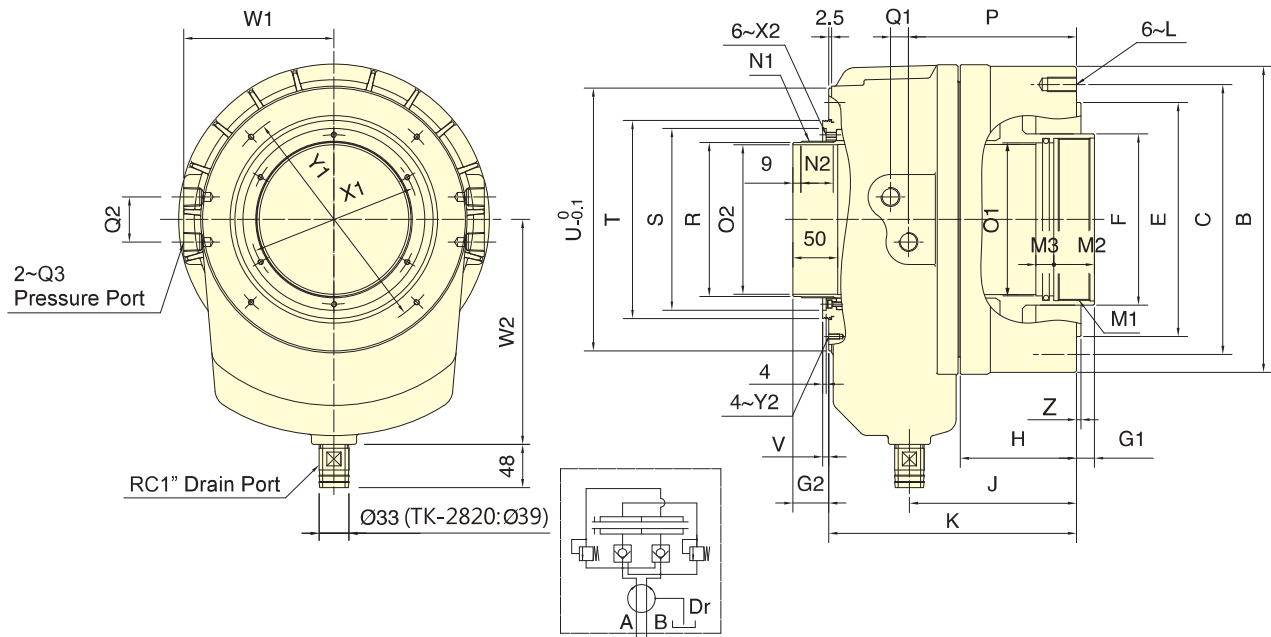

Subject to technical changes

SPECIFICATIONS

Model	Eff. piston area		Piston stroke	Max. speed	Max. pressure	I	Weight	Total oil leakage
	Extend	Retract						
	cm ²	cm ²						
TK-2416	418.4	375.4	35	2000	3.0 (30)	1.12	78.0	9.0
TK-2416L	418.4	375.4	51	2000	3.0 (30)	1.31	79.2	9.0
TK-2820	526.2	472.6	51	1600	3.0 (30)	2.4	134.0	10.0

DIMENSIONS

Model	A	B	C	E	F	G1		G2		H	J	K	L	M1	M2	M3	N1	N2
	I.D.			h7		max.	min.	max.	min.									
TK-2416	290	340	300	260	190	35	0	60	25	129	185.5	275	M16x32	M180x3	45	20	M174x2	38
TK-2416L	290	340	300	260	190	51	0	76	25	145	201.5	291	M16x32	M180x3	45	20	M174x2	52
TK-2820	340	395	360	320	235	51	0	76	25	152	212.5	316	M20x40	M220x3	45	20	M218x2	52

Model	O1	O2	P	Q1	Q2	Q3	R	S	T	U	V	W1	W2	X1	X2	Y1	Y2	Z
	H8	H8					g7	H7										
TK-2416	170	166	186.5	20	50	RC1/2	171	202	220	292	7	167	250	188	M6x11	260	M6x12	5
TK-2416L	170	166	202.5	20	50	RC1/2	171	202	220	292	7	167	250	188	M6x11	260	M6x12	6
TK-2820	210	205	216	21	50	RC1/2	215	262	285	360	7	202.5	300	240	M6x12	320	M6x12	6



- Bigger bore through-hole design.
- Super short form, light weighted.
- Built-in safety check valves and pressure relief valves.
- Front / Rear end mounting.
- Diameter of coolant collector's drain port is optional.
Default : Ø33 ; optional : Ø40, Ø60.
- Patent numbers :
Taiwan : PAT.NO.M491534
China : PAT.NO.ZL201420584274.5

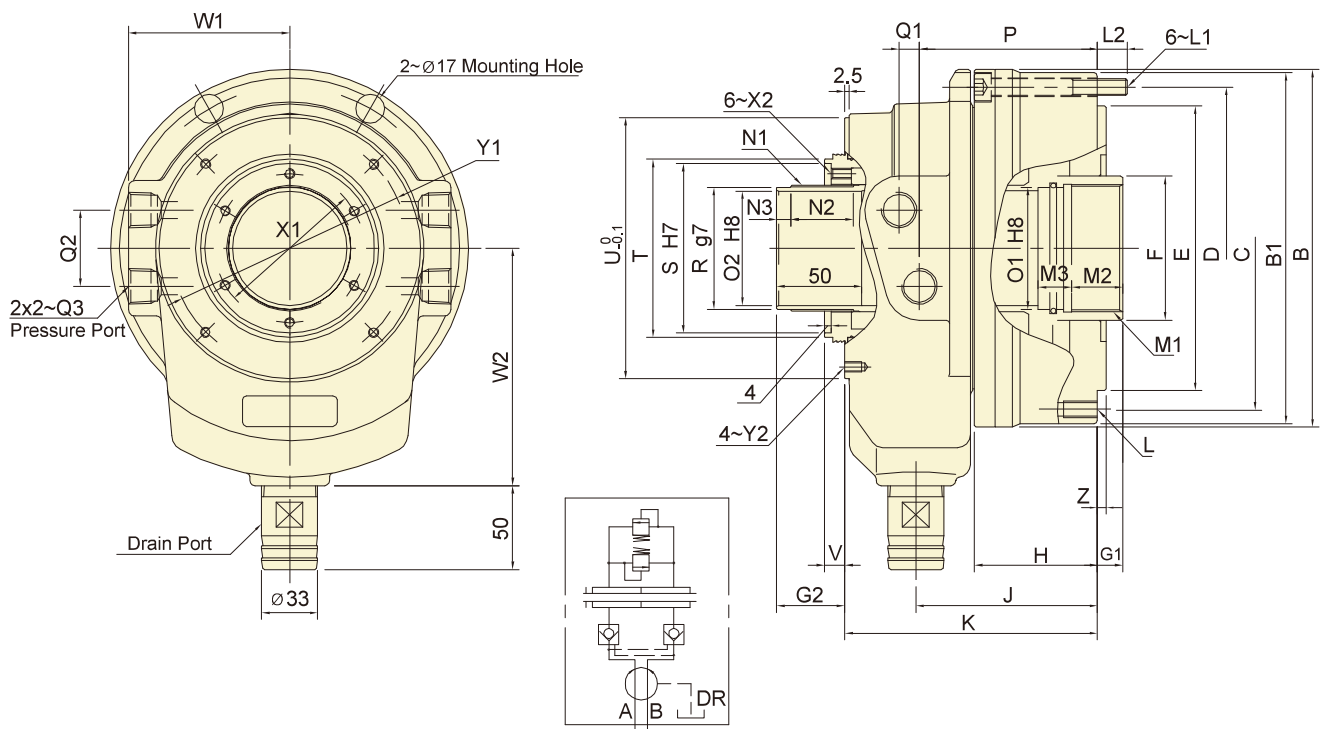

ROTARY CYLINDERS

Subject to technical changes

SPECIFICATIONS

Model	Eff. piston area		Piston stroke	Max. speed	Max. pressure	I	Weight	Total oil leakage
	Extend	Retract						
	cm ²	cm ²				kg·m ²		
NEW TS-866	168	155.5	25	5600	45	0.056	16.5	4

DIMENSIONS

Model	A	B	B1	C	D	E	F	G1		G2		H	J	K	L	L1	L2	M1	M2	M3
	I.D.					h7		max.	min.	max.	min.									
NEW TS-866	160	211	207	190	190	168	85	25	0	55	30	72.5	107	149	12~M10x20	M10x80	17.5	M75x2	35	15

Model	N1	N2	N3	O1	O2	P	Q1	Q2	Q3	R	S	T	U	V	W1	W2	X1	X2	Y1	Y2	Z
				(H8)	(H8)					(g7)	(H7)										
NEW TS-866	M74x1.5	37	8	72	66.5	105	12	45	RC1/2	72	100	111	154	12	95	140	88	M6x12	140	M6x10	5

- Super high speed, light weight large Through-Hole.
- Built-in check valve which prevents the internal pressure from sudden declining so that the workpiece will not fly out and cause a serious accident.

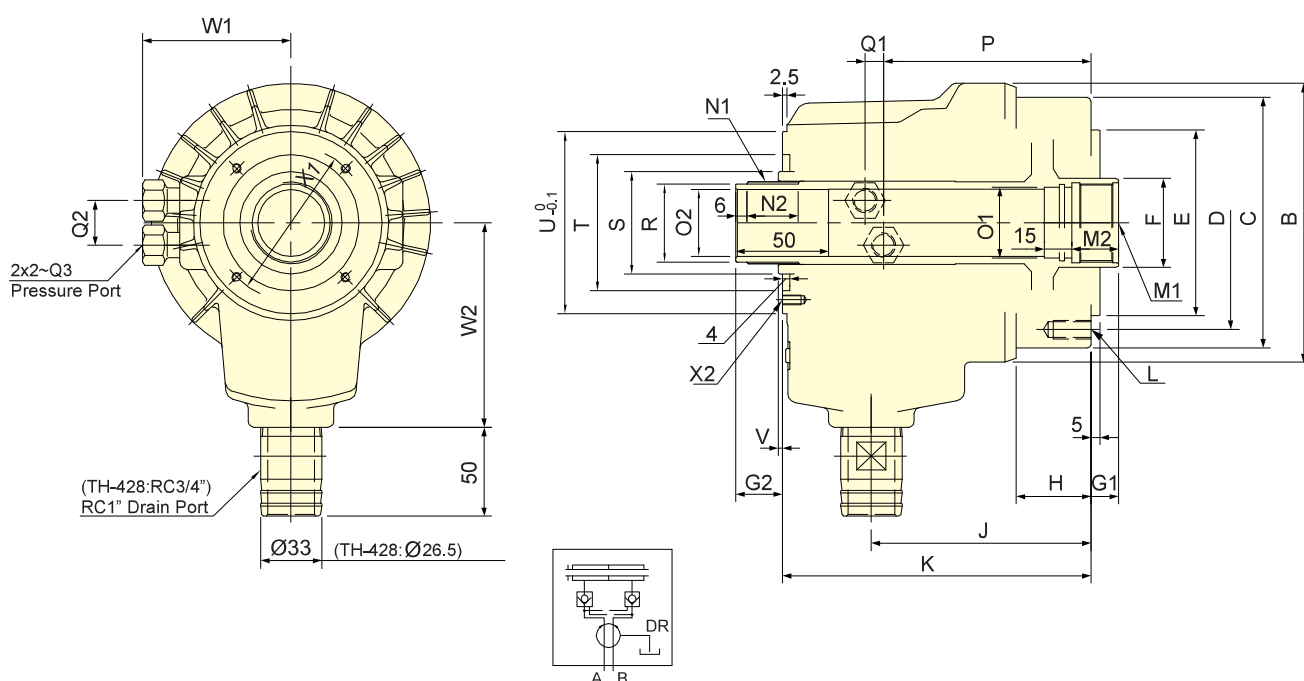

Subject to technical changes

SPECIFICATIONS

Model	Eff. piston area		Piston stroke	Max. speed	Max. pressure	I	Weight	Total oil leakage
	Extend	Retract						
	cm ²	cm ²				kg·m ²		
TH-428	53.2	50.5	10	8000	4.0(40)	0.008	5.8	3.0
TH-A536	69.8	67.5	15	8000	4.0(40)	0.05	8.3	3.0

DIMENSIONS

Model	A I.D.	B	C	D	E (h7)	F	G1 max.	G1 min.	G2 max.	G2 min.	H	J	K	L	M1	M2	N1	N2
TH-428	90	130	120	100	80	40	10	0	35	25	45	127.5	155	6-M8x15	M33x1.5	25	M34x1.5	26
TH-A536	105	150	135	115	100	48	15	0	40	25	40	118	166	6-M10x20	M42x1.5	25	M44x1.5	28

Model	O1 (H8)	O2 (H8)	P	Q1	Q2	Q3	R (g7)	S	T	U	V	W1	W2	X1	X2
TH-428	30	28	101.5	11	24	RC1/4	32	45	65	86	4	72	105	76	M4x7
TH-A536	38	36	111.5	10	24	RC1/4	42	55	73	98	4	80	110	83	M5x10



- This is a compact, short form, light weight through-hole rotary cylinder.
 - With patented build-in safety check valves and pressure relief valves.
 - Large feed port and drain port, large input and keep drain smoothly.
 - Can be screwed from the front end or rear end of cylinder when mounting.
 - For use with vertical or horizontal spindles.
- Patent numbers :
 Taiwan : PAT.NO.M491534
 China : PAT.NO.ZL201420584274.5

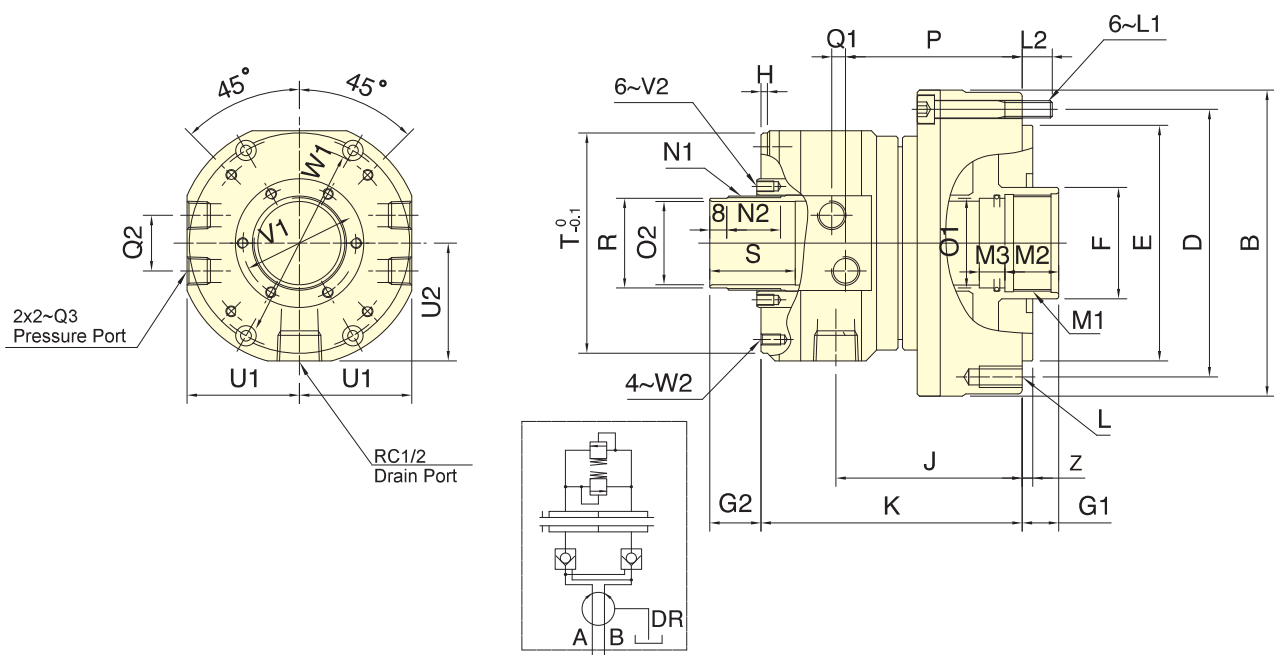

Subject to technical changes

SPECIFICATIONS

Model	Eff. piston area		Piston stroke mm	Max. speed min ⁻¹ (r.p.m.)	Max. pressure MPa(kgf/cm ²)	I Moment of inertia kg·m ²	Weight kg	Total oil leakage lit. / min.
	Extend cm ²	Retract cm ²						
	TR-539	72.4						
TR-646	105.0	93.9	15	7000	4.0(40)	0.015	9.5	3.0

DIMENSIONS

Model	A	B	C	D	E	F	G1		G2		H	J	K	L	L1	L2	M1	M2
	I.D.				h7		max.	min.	max.	min.								
TR-539	107	143	125	125	110	52	15	0	34	19	4	97	133	6-M10x20	M8x60	12	M45x1.5	25
TR-646	128	165	147	147	130	65	15	0	34	19	3.5	97	135	12-M10x20	M8x60	11.5	M55x2	25

Model	M3	N1	N2	O1	O2	P	Q1	Q2	Q3	R	S	T	U1	U2	V1	V2	W1	W2	Z
				H8	H8					g7									
TR-539	12	M44x1.5	25	42	39	92.5	6.5	26	RC1/4	42	40	103	52.5	55	53	M5x8	90	M5x9	5
TR-646	13	M52x1.5	25	50	46	93	6.5	32	RC3/8	50	50	116	59	62	61.5	M5x9	98	M5x9	5



- For short form, light weight and high speed rotary cylinder.
- Built-in safety check valves and pressure relief valves.
- Can screw it from the rear end of the cylinder when mounting.
- The drain port should be independently connected to oil tank to avoid back pressure.

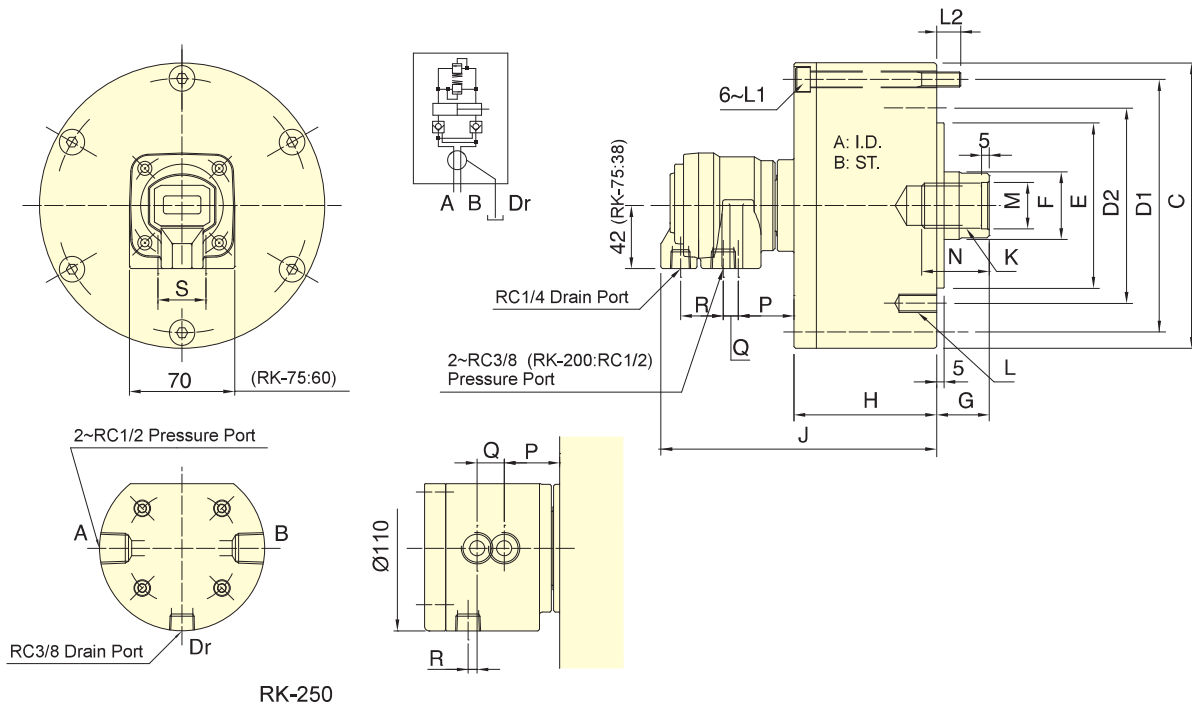

RK-250

Subject to technical changes

SPECIFICATIONS

Model	Eff. piston area		Piston stroke	Max. speed	Max. pressure	I Moment of inertia	Weight
	Extend cm ²	Retract cm ²					
RK-75	44.2	37.1	15	6000	4.0 (40)	0.01	2.9
RK-100	78.5	71.5	20	6000	4.0 (40)	0.03	4.4
RK-125	122.7	113.1	25	6000	4.0 (40)	0.05	6.9
RK-150	176.7	160.8	30	5500	4.0 (40)	0.09	9.5
RK-200	314.1	290.4	35	5500	4.0 (40)	0.28	15.4
RK-250	469.1	436.0	60	2000	5.0(50)	0.40	45.2

DIMENSIONS

Model	A	B	C	D1	D2	E (h7)	F	G max.	G min.	H	J	K	L	L1	L2	M (H8)	N	P	Q	R	S
RK-75	75	15	107	90	90	65	30	45	30	57	148	M20x2.5	6-M8x16	M8x60	12	21	35	41.5	10	27.5	26
RK-100	100	20	132	115	100	80	30	45	25	72	163	M20x2.5	6-M10x20	M8x75	12	21	35	39.5	10	28.5	32
RK-125	125	25	160	140	130	110	35	50	25	82	172	M24x3.0	6-M12x20	M8x85	12	25	45	38.5	10	28.5	32
RK-150	150	30	190	170	130	110	45	55	25	95	184	M30x3.5	12-M12x24	M10x100	16	32	45	37	10	28.5	32
RK-200	200	35	245	220	145	120	55	70	35	115	201	M36x4.0	12-M16x30	M10x125	21	38	60	38	6	28.5	28
RK-250	245	60	307	275	220	160	65	85	25	165	255	M42x3.0	12-M20x35	M16x175	28	45	65	33	18	6	-

- For short form, light weight and high speed rotary cylinder.
- Can screw it from the rear end of the cylinder when mounting.
- The drain port should be independently connected to oil tank to avoid back pressure.

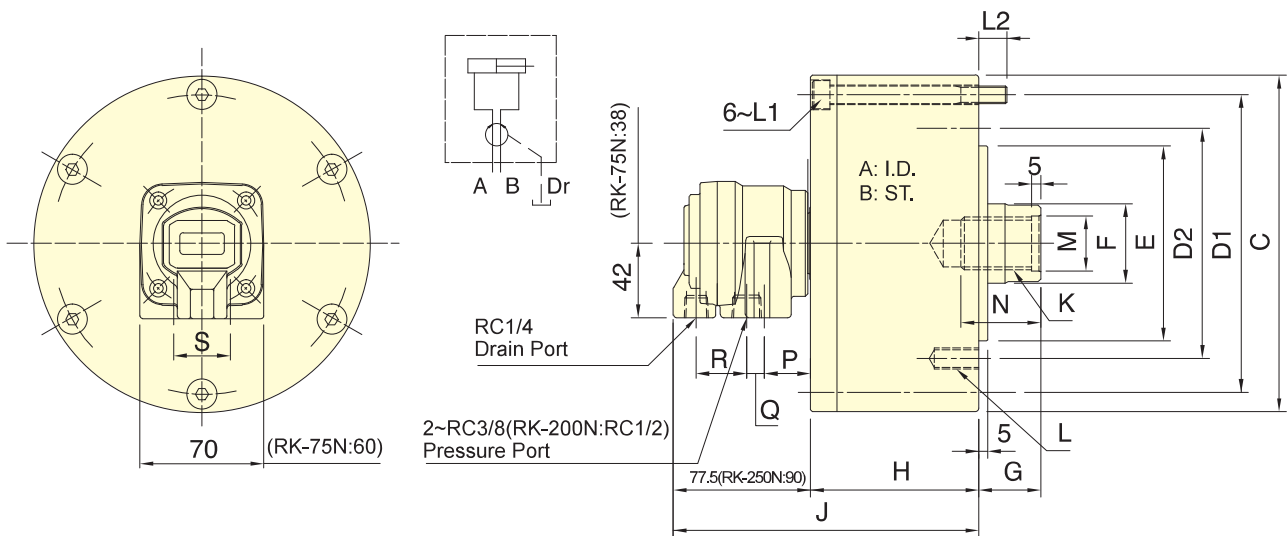

Subject to technical changes

SPECIFICATIONS

Model	Eff. piston area		Piston stroke	Max. speed	Max. pressure	I Moment of inertia	Weight
	Extend cm ²	Retract cm ²					
RK-75N	44.2	37.1	15	6000	4.0(40)	0.01	2.8
RK-100N	78.5	71.5	20	6000	4.0(40)	0.03	4.3
RK-125N	122.7	113.1	25	6000	4.0(40)	0.05	6.8
RK-150N	176.7	160.8	30	5500	4.0(40)	0.09	9.4
RK-200N	314.1	290.4	35	5500	4.0(40)	0.28	15.3
RK-250N	469.1	436.0	60	2000	5.0(50)	0.40	45.2

DIMENSIONS

Model	A	B	C	D1	D2	E (h7)	F	G max.	G min.	H	J	K	L	L1	L2	M (H8)	N	P	Q	R	S
RK-75N	75	15	107	90	90	65	30	45	30	57	134.5	M20x2.5	6~M8x16	M8x60	12	21	35	28	10	27.5	26
RK-100N	100	20	132	115	100	80	30	45	25	72	149.5	M20x2.5	6~M10x20	M8x75	12	21	35	26	10	28.5	32
RK-125N	125	25	160	140	130	110	35	50	25	82	159.5	M24x3.0	6~M12x20	M8x85	12	25	45	26	10	28.5	32
RK-150N	150	30	190	170	130	110	45	55	25	95	172.5	M30x3.5	12~M12x24	M10x100	16	32	45	26	10	28.5	32
RK-200N	200	35	245	220	145	120	55	70	35	115	192.5	M36x4.0	12~M16x30	M10x125	21	38	60	30	6	28.5	28
RK-250N	245	60	307	275	220	160	65	85	25	165	255	M42x3.0	6~M20x2.5	M16x175	28	45	65	37	18	6	-



- The rotary valve and cylinder body, all made of special light alloy, light-weight.
- Through unique design, the rotary valve enables the inside bearing to get sufficient lubricating and cooling and endure high-speed rotary for longer service life.
- The drain port should be independently connected to oil tank to avoid back pressure.

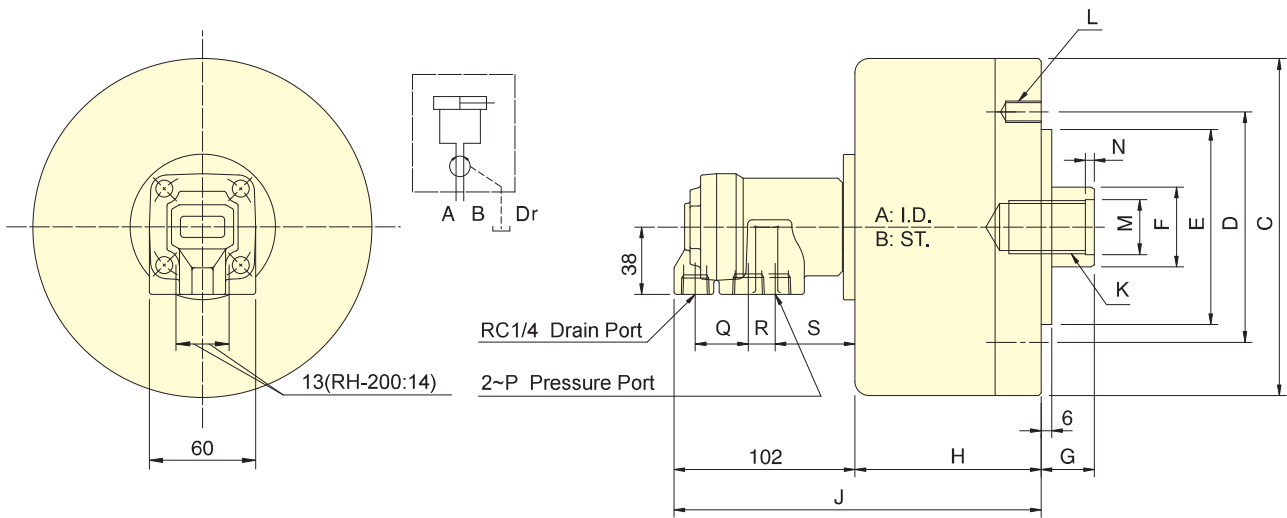

Subject to technical changes

SPECIFICATIONS

Model	Eff. piston area		Piston stroke	Max. speed	Max. pressure	I	Weight
	Extend	Retract					
	cm ²	cm ²				mm	
RH-65	31.0	27.9	15	6000	3.5(35)	0.01	2.9
RH-80	47.7	42.8	15	6000	3.5(35)	0.01	3.4
RH-100	75.4	70.5	20	5500	3.5(35)	0.04	4.9
RH-125	119.6	112.5	25	5500	3.5(35)	0.08	6.8
RH-200	310.0	286.3	35	4000	4.0(40)	0.38	20.4

DIMENSIONS

Model	A	B	C	D	E (h7)	F	G max.	G min.	H	J	K	L	M (H8)	N	P	Q	R	S
RH-65	65	15	98	80	60	22	45	30	73	175	M12x1.75x30	6~M8x16	14	4	RC3/8	30	15	45
RH-80	80	15	112	90	65	25	45	30	74	176	M16x2.0x30	6~M8x16	17	4	RC3/8	30	15	45
RH-100	100	20	135	100	80	25	45	25	88.5	190.5	M16x2.0x30	6~M10x20	17	4	RC3/8	30	15	45
RH-125	125	25	160	130	110	30	50	25	95.5	197.5	M20x2.5x35	6~M12x20	21	4	RC3/8	30	15	45
RH-200	200	35	245	145	120	55	70	35	130	232	M36x4	12~M16x30	38	5	RC1/2	31	16	43



- The rotary valve and cylinder body, all made of special light alloy, are light-weight.
- Through unique design, the rotary valve can considerably reduce the waste in compressing air and efficiently increase its utilization.
- When used, a little oil mist should be contained.

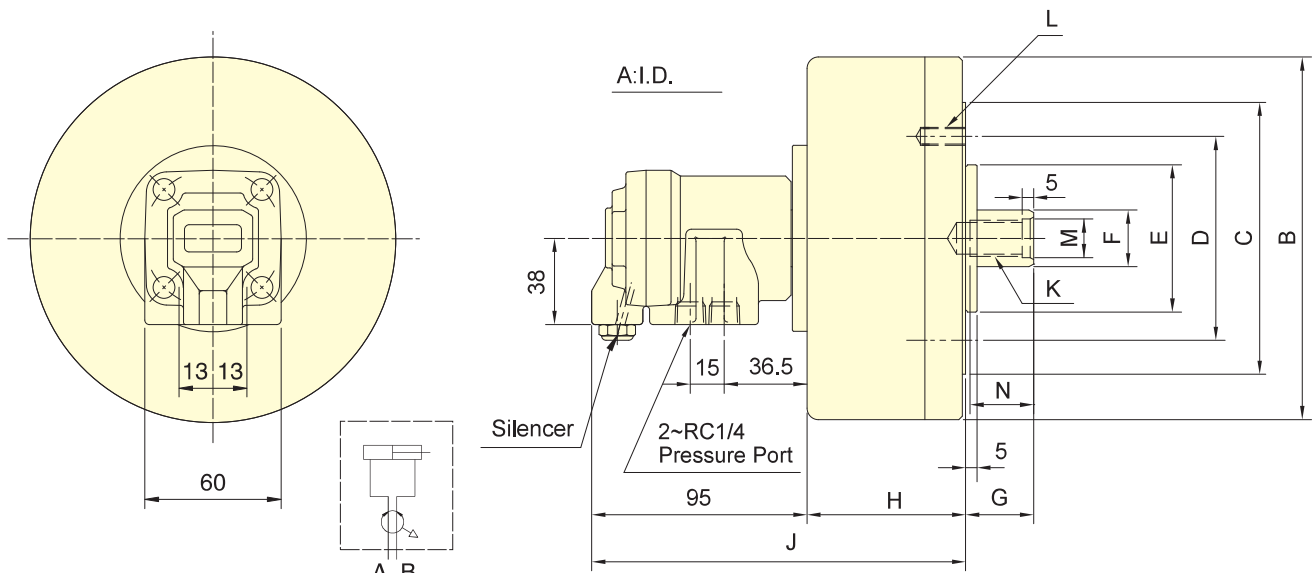

Subject to technical changes

SPECIFICATIONS

Model	Eff. piston area		Piston stroke mm	Max. speed min ⁻¹ (r.p.m.)	Max. pressure MPa(kgf/cm ²)	I Moment of inertia kg·m ²	Weight kg	Air Leakage (6kgf/cm ²) cc/sec
	Extend cm ²	Retract cm ²						
	RA-100	77.0				74.4		
RA-130	131.2	124.7	15	5000	0.8(8)	0.05	5.2	400
RA-170	225.4	219.0	20	5000	0.8(8)	0.18	8.5	400
RA-220	378.6	369.3	25	4000	0.8(8)	0.36	14.5	400
RA-270	571.0	562.9	30	3000	0.8(8)	0.75	18.4	400

DIMENSIONS

Model	A	B	C	D	E (h7)	F	G max.	G min.	H	J	K	L	M (H8)	N
RA-100	100	130	-	80	60	22	50	35	65	160	M12x1.75	6-M8x16	13	25
RA-130	130	160	120	90	65	25	45	30	70	165	M16x2.0	6-M8x16	17	30
RA-170	170	200	140	100	80	25	45	25	85	180	M16x2.0	6-M10x18	17	30
RA-220	220	255	170	130	110	30	50	25	91	186	M20x2.5	6-M12x20	21	35
RA-270	270	305	190	130	110	35	55	25	105	200	M24x3.0	6-M12x20	25	40



- For short form, high speed and stroke control.
- With proximity sensor , the movement of the position is easy to adjust and confirm when operating.
- Built-in safety check valves and pressure relief valves.
- Can screw it from the rear end of the cylinder when mounting.
- The drain port should be independently connected to oil tank to avoid back pressure.

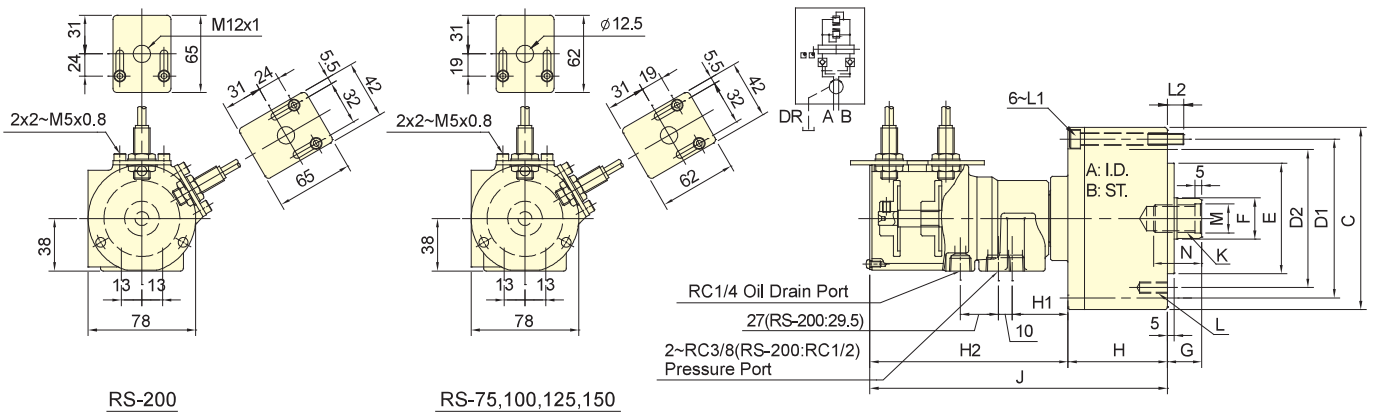

RS-200

RS-75, 100, 125, 150

Subject to technical changes

SPECIFICATIONS

Model	Eff. piston area		Piston stroke mm	Max. speed min ⁻¹ (r.p.m.)	Max. pressure MPa(kgf/cm ²)	I Moment of inertia kg·m ²	Weight kg
	Extend cm ²	Retract cm ²					
	RS-75	43.0				37.1	
RS-100	77.4	71.5	20	6000	4.0 (40)	0.04	4.9
RS-125	121.6	113.1	25	6000	4.0 (40)	0.05	7.4
RS-150	175.6	160.8	30	5500	4.0 (40)	0.10	10.7
RS-200	313.0	290.4	35	5500	4.0 (40)	0.29	15.9

DIMENSIONS

Model	A	B	C	D1	D2	E (h7)	F	G max.	G min.	H	H1	H2	J	K	L	L1	L2	M (H8)	N
RS-75	75	15	107	90	90	65	30	45	30	57	42	145	202	M20x2.5	6~M8x16	M8x60	12	21	35
RS-100	100	20	132	115	100	80	30	45	25	72	42	145	217	M20x2.5	6~M10x20	M8x75	12	21	35
RS-125	125	25	160	140	130	110	35	50	25	82	41	144	226	M24x3.0	6~M12x20	M8x85	12	25	45
RS-150	150	30	190	170	130	110	45	55	25	95	39	142	237	M30x3.5	12~M12x24	M10x100	16	32	45
RS-200	200	35	245	220	145	120	55	70	35	115	34	142.5	257.5	M36x4.0	12~M16x30	M10x125	21	38	60

Proximity sensor : Model IFS287(IFM) DC 10-30V 100mA NPN .



- For short form, high speed and stroke control.
- With proximity sensor, the movement of the position is easy to adjust and confirm when operating.
- Can screw it from the rear end of the cylinder when mounting.
- The drain port should be independently connected to oil tank to avoid back pressure.

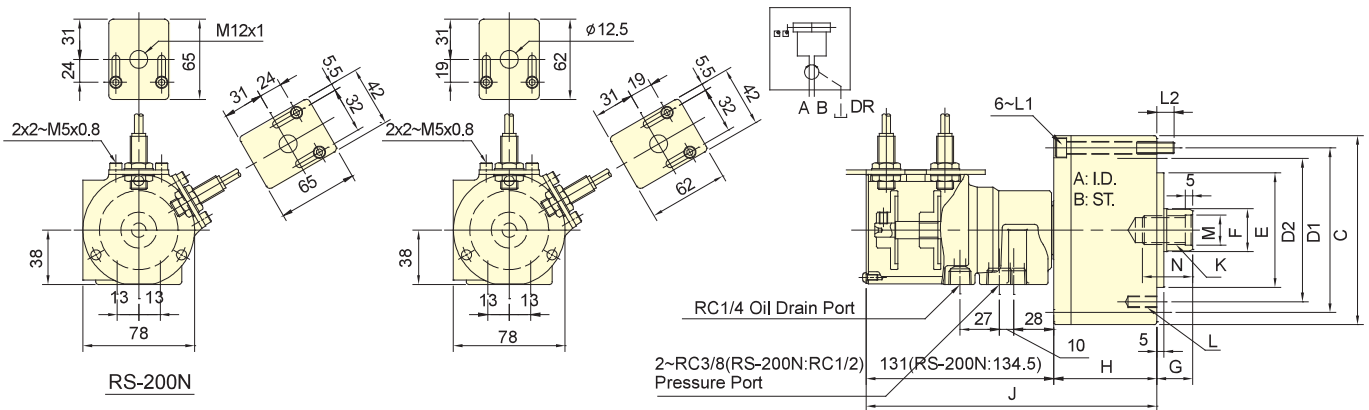

Subject to technical changes

SPECIFICATIONS

Model	Eff. piston area		Piston stroke	Max. speed	Max. pressure	I	Weight
	Extend	Retract					
	cm ²	cm ²				mm	
RS-6520N	32.0	28.3	20	6000	4.0(40)	0.01	3.2
RS-6530N	32.0	28.3	30	6000	4.0(40)	0.01	3.3
RS-75N	43.0	37.1	15	6000	4.0(40)	0.01	3.3
RS-7530N	43.0	37.1	30	6000	4.0(40)	0.013	3.7
RS-100N	77.4	71.5	20	6000	4.0(40)	0.04	4.8
RS-125N	121.6	113.1	25	6000	4.0(40)	0.05	7.3
RS-150N	175.6	160.8	30	5500	4.0(40)	0.16	10.6
RS-200N	313.0	290.4	35	5500	4.0(40)	0.29	15.9

DIMENSIONS

Model	A	B	C	D1	D2	E (h7)	F	G max.	G min.	H	J	K	L	L1	L2	M (H8)	N
RS-6520N	65	20	97	80	80	60	25	45	25	62	193	M16x2.0	6~M8x16	M6x70	14.5	17	30
RS-6530N	65	30	97	80	80	60	25	45	15	62	203	M16x2.0	6~M8x16	M6x80	14.5	17	30
RS-75N	75	15	107	90	90	65	30	45	30	57	188	M20x2.5	6~M8x16	M8x60	12	21	35
RS-7530N	75	30	107	90	90	65	30	45	15	72	203	M20x2.5	6~M8x16	M8x75	12	21	35
RS-100N	100	20	132	115	100	80	30	45	25	72	203	M20x2.5	6~M10x20	M8x75	12	21	35
RS-125N	125	25	160	140	130	110	35	50	25	82	213	M24x3.0	6~M12x20	M8x85	12	25	45
RS-150N	150	30	190	170	130	110	45	55	25	95	226	M30x3.5	12~M12x24	M10x100	16	32	45
RS-200N	200	35	245	220	145	120	55	75	35	115	249.5	M36x4.0	12~M16x30	M10x125	21	38	60

Proximity sensor : Model IFS287(IFM) DC 10-30V 100mA NPN .



- To allow coolant to be feed from the rear end of the distributor through the rotating union
- Built-in safety check valves and pressure relief valves.
- The drain port should be independently connected to oil tank to avoid back pressure.
- The rotary cylinder should not run without liquid through coolant port.

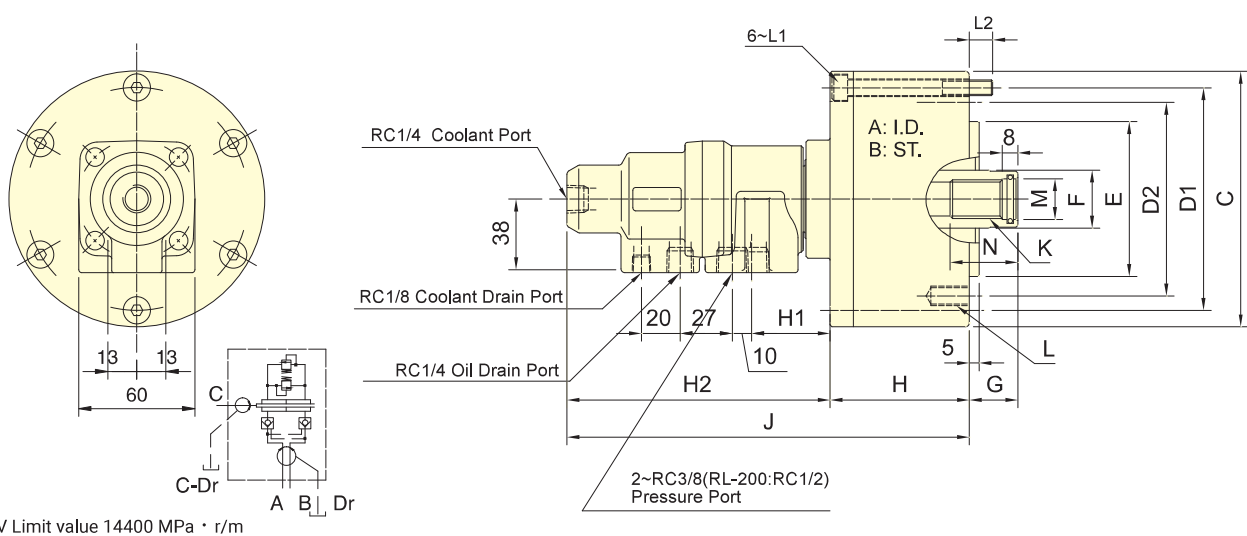

PV Limit value 14400 MPa · r/m

Subject to technical changes

SPECIFICATIONS

Model	Eff. piston area		Piston stroke	Max. speed	Max. pressure	Coolant connection Max. pressure	I Moment of inertia	Weight
	Extend	Retract						
	cm ²	cm ²						
RL-75	42.6	37.1	15	6000	4.0(40)	3.5(35)	0.01	3.1
RL-100	77.0	71.5	20	6000	4.0(40)	3.5(35)	0.04	4.6
RL-125	121.2	113.1	25	6000	4.0(40)	3.5(35)	0.06	7.1
RL-150	175.2	160.8	30	5500	4.0(40)	3.5(35)	0.10	9.7
RL-200	312.5	290.4	35	5500	4.0(40)	3.5(35)	0.30	15.6

DIMENSIONS

Model	A	B	C	D1	D2	E (h7)	F	G max.	G min.	H	H1	H2	J	K	L	L1	L2	M (H8)	N
RL-75	75	15	107	90	90	65	30	45	30	57	42	137	194	M20x2.5	6~M8x16	M8x60	12	21	35
RL-100	100	20	132	115	100	80	30	45	25	72	42	137	209	M20x2.5	6~M10x20	M8x75	12	21	35
RL-125	125	25	160	140	130	110	35	50	25	82	41	136	218	M24x3.0	6~M12x20	M8x85	12	25	45
RL-150	150	30	190	170	130	110	45	55	25	95	39	134	230	M30x3.5	12~M12x24	M10x100	16	32	45
RL-200	200	35	245	220	145	120	55	70	35	115	36	132	248	M36x4.0	12~M16x30	M10x125	21	38	60



- To allow compressed air to be feed from the rear end of the distributor through the rotating union.
- Can screw it from the rear end of the cylinder when mounting.
- When used, a little oil mist should be contained.

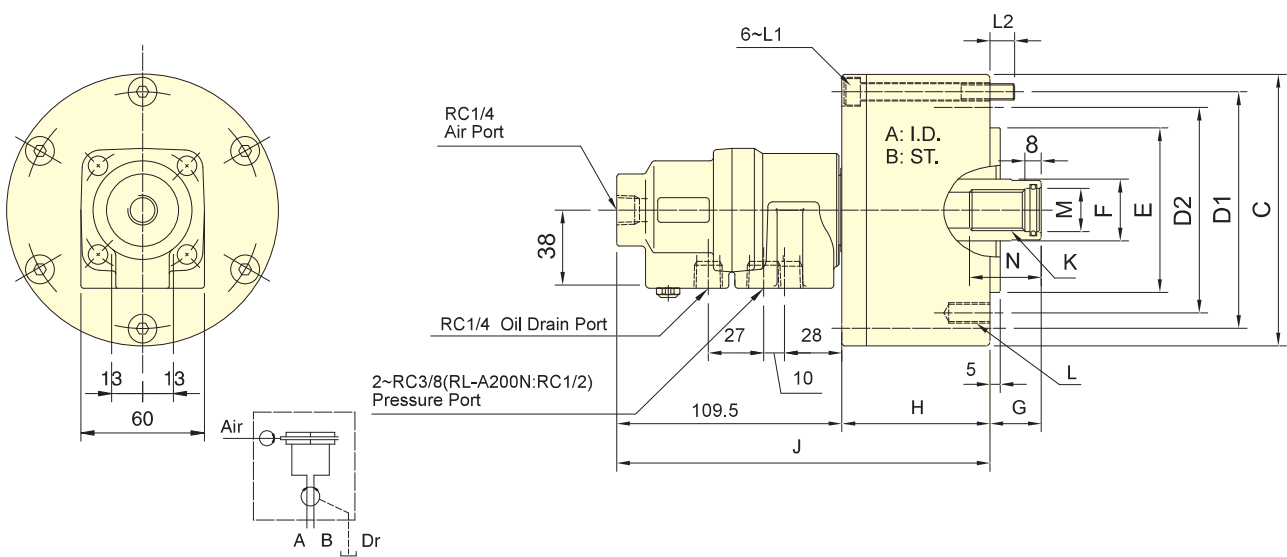

Subject to technical changes

SPECIFICATIONS

Model	Eff. piston area		Piston stroke mm	Max. speed min ⁻¹ (r.p.m.)	Max. pressure MPa(kgf/cm ²)	Air connection Max. pressure MPa (kgf/cm ²)	I Moment of inertia kg·m ²	Weight kg
	Extend cm ²	Retract cm ²						
	RL- A75N	42.6					37.1	
RL- A100N	77.0	71.5	20	6000	4.0(40)	0.8(8)	0.04	4.5
RL- A125N	121.2	113.1	25	6000	4.0(40)	0.8(8)	0.06	7.0
RL- A150N	175.2	160.8	30	5500	4.0(40)	0.8(8)	0.10	9.6
RL- A200N	312.5	290.4	35	5500	4.0(40)	0.8(8)	0.29	15.5

DIMENSIONS

Model	A	B	C	D1	D2	E (h7)	F	G max.	G min.	H	J	K	L	L1	L2	M (H8)	N
RL- A75N	75	15	107	90	90	65	30	45	30	57	166	M20 x2.5	6~M8x 16	M8x60	12	21	35
RL- A100N	100	20	132	115	100	80	30	45	25	72	181	M20 x2.5	6~M10x20	M8x75	12	21	35
RL- A125N	125	25	160	140	130	110	35	50	25	82	191	M24x 3.0	6~M12x20	M8x85	12	25	45
RL- A150N	150	30	190	170	130	110	45	55	25	95	204	M30x3.5	12~M12x24	M10x100	16	32	45
RL- A200N	200	35	245	220	145	120	55	70	35	115	225	M36 x4.0	12~M16x30	M10x125	21	38	60



- For short form, light weight and high speed rotary cylinder.
- Built-in safety check valves, pressure relief valves and proximity sensor.
- Can screw it from the rear end of the cylinder when mounting.
- The drain port should be independently connected to oil tank to avoid back pressure.

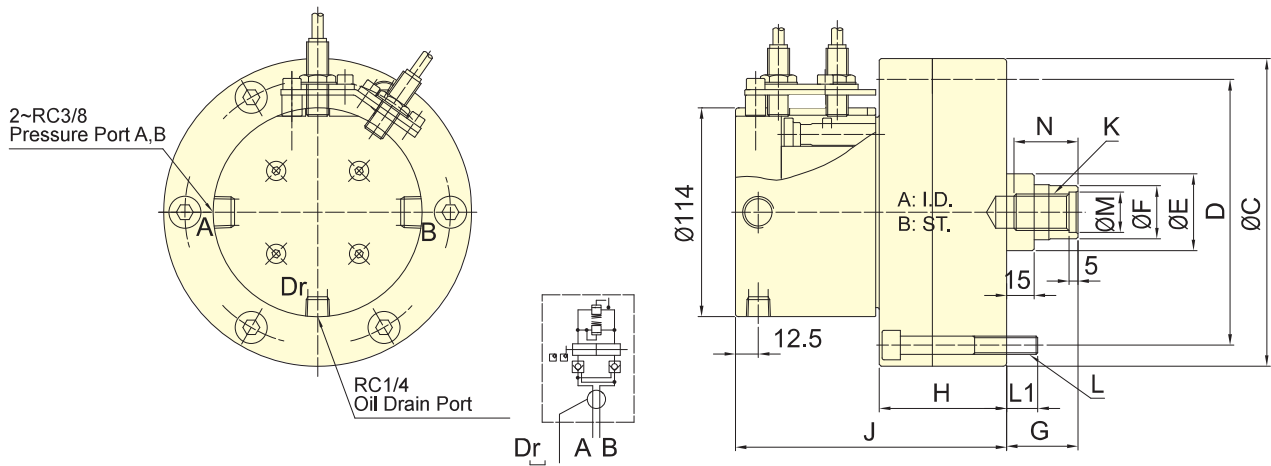

Subject to technical changes

SPECIFICATIONS

Model	Eff. piston area		Piston stroke	Max. speed	Max. pressure	I	Weight
	Extend	Retract					
	cm ²	cm ²				mm	
RE-110	92.7	87.9	20	6000	3.5(35)	0.02	6.9
RE-120	110.8	106	21	6000	4.0(40)	0.03	8.8
RE-130	130.4	123.1	30	6000	4.0(40)	0.03	9.1

DIMENSIONS

Model	A	B	C (h7)	D	E	F	G max.	G min.	H	J	K	L	L1	M (H8)	N
RE-110	110	20	145	128	42	29	60	40	66	146	M20x2.5	6~M8x70	12	22	35
RE-120	120	21	168	145	42	29	60	39	69.5	148	M20x2.5	6~M10x75	17	22	35
RE-130	130	30	168	150	50	33	60	30	79.5	158	M24x3.0	6~M10x85	17	27	40



- For short form, light weight and high speed rotary cylinder, suitable for vertical lathe.
- Built-in safety check valves, pressure relief valves and proximity sensor.
- Can screw it from the rear end of the cylinder when mounting.
- The drain port should be independently connected to oil tank to avoid back pressure.

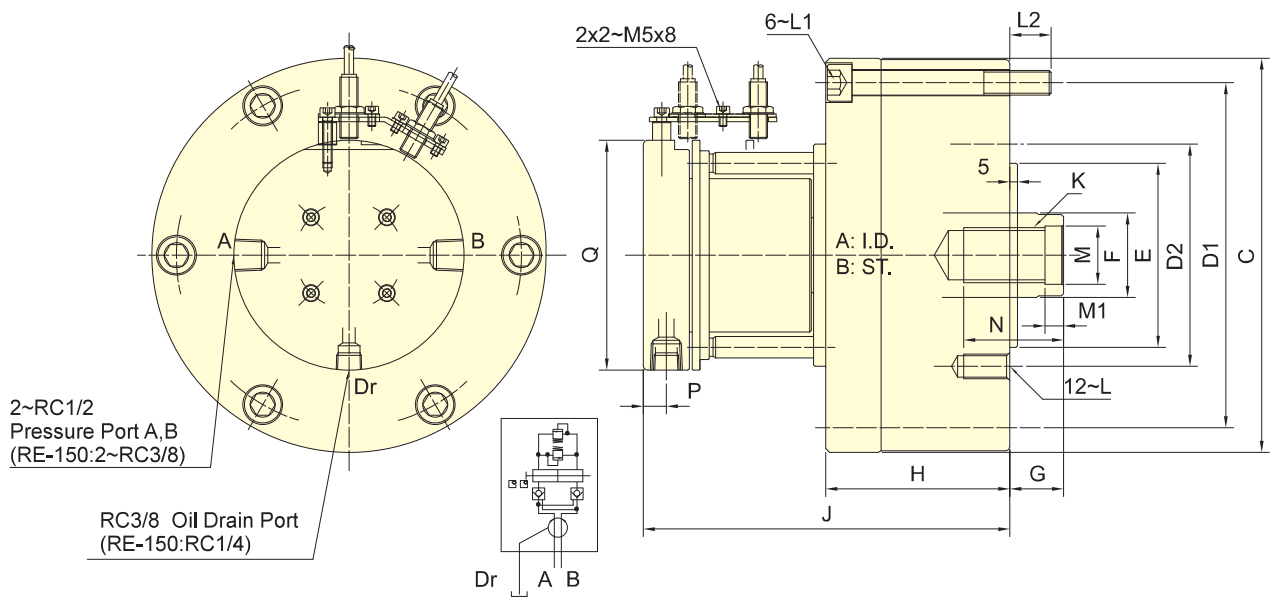

Subject to technical changes

SPECIFICATIONS

Model	Eff. piston area		Piston stroke	Max. speed	Max. pressure	I	Weight
	Extend	Retract					
	cm ²	cm ²				kg·m ²	
RE-150	174.4	160.8	30	5500	4.0 (40)	0.06	14.9
RE-200K	292.4	274.9	35	4000	4.0 (40)	0.19	29.1
RE-200L	292.4	265.4	50	4000	5.0 (50)	0.21	30.4
RE-250	465.2	438.2	60	2000	5.0 (50)	0.43	47.2

DIMENSIONS

Model	A	B	C	D1	D2	E (h7)	F	G max.	G min.	H	J	K	L	L1	L2	M (H8)	M1	N	P	Q
RE-150	150	30	205	180	130	110	45	60	30	99	177.5	M30x3.5	M12x24	M12x105	18.5	32	10	50	12.5	114
RE-200K	195	35	257	225	145	120	55	73	38	120	239	M36x4.0	M16x30	M16x130	27	38	12	65	15	150
RE-200L	195	50	257	225	170	125	65	80	30	135	254	M42x3.0	M16x30	M16x145	27	45	12	65	15	150
RE-250	245	60	307	275	220	160	65	85	25	165	280	M42x3.0	M20x35	M16x175	28	45	12	65	15	150



- For short form, light weight and high speed rotary cylinder. To allow compressed air to be feed from the rear end of the distributor through the rotating union.
- Built-in safety check valves, pressure relief valves and proximity sensor.
- Can screw it from the rear end of the cylinder when mounting.
- The drain port should be independently connected to oil tank to avoid back pressure.
- When used, a little oil mist should be contained.

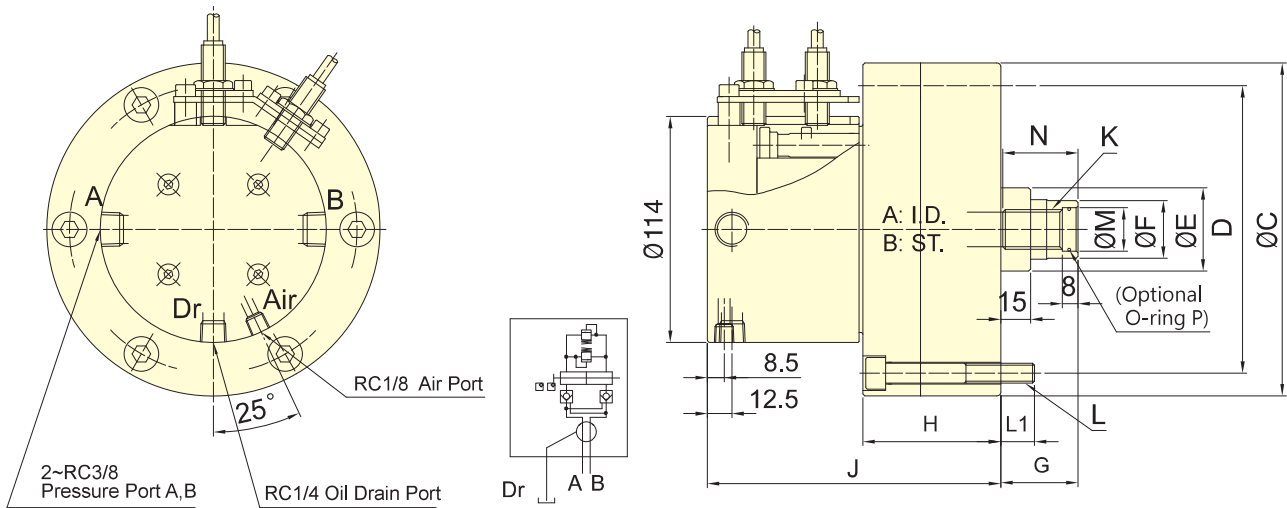

Subject to technical changes

SPECIFICATIONS

Model	Eff. piston area		Piston stroke mm	Max. speed min ⁻¹ (r.p.m.)	Max. pressure MPa(kgf/cm ²)	Coolant connection Max. pressure MPa (kgf/cm ²)	I		Weight kg
	Extend cm ²	Retract cm ²					Moment of inertia kg·m ²		
RE-A110	91.2	87.9	20	6000	4.0(40)	0.8(8)	0.02	0.02	6.9
RE-A120	109.3	106	21	6000	4.0(40)	0.8(8)	0.02	0.02	8.8
RE-A130	128.9	123.1	30	6000	4.0(40)	0.8(8)	0.03	0.03	9.1

DIMENSIONS

Model	A	B	C (h7)	D	E	F	G max.	G min.	H	J	K	L	L1	M (H8)	N	P
RE-A110	110	20	145	128	42	29	60	40	66	146	M20x2.5	6~M8x70	12	22	38	S20
RE-A120	120	21	168	145	42	29	60	39	69.5	148	M20x2.5	6~M10x75	17	22	38	S20
RE-A130	130	30	168	150	50	33	60	30	79.5	158	M24x3.0	6~M10x85	17	27	43	S24

Proximity sensor : Model IFS287(IFM) DC 10-30V 100mA NPN .



- For short form, light weight and high speed rotary cylinder. To allow compressed air to be feed from the rear end of the distributor through the rotating union.
- Built-in safety check valves, pressure relief valves and proximity sensor.
- Can screw it from the rear end of the cylinder when mounting.
- The drain port should be independently connected to oil tank to avoid back pressure.
- When used, a little oil mist should be contained.

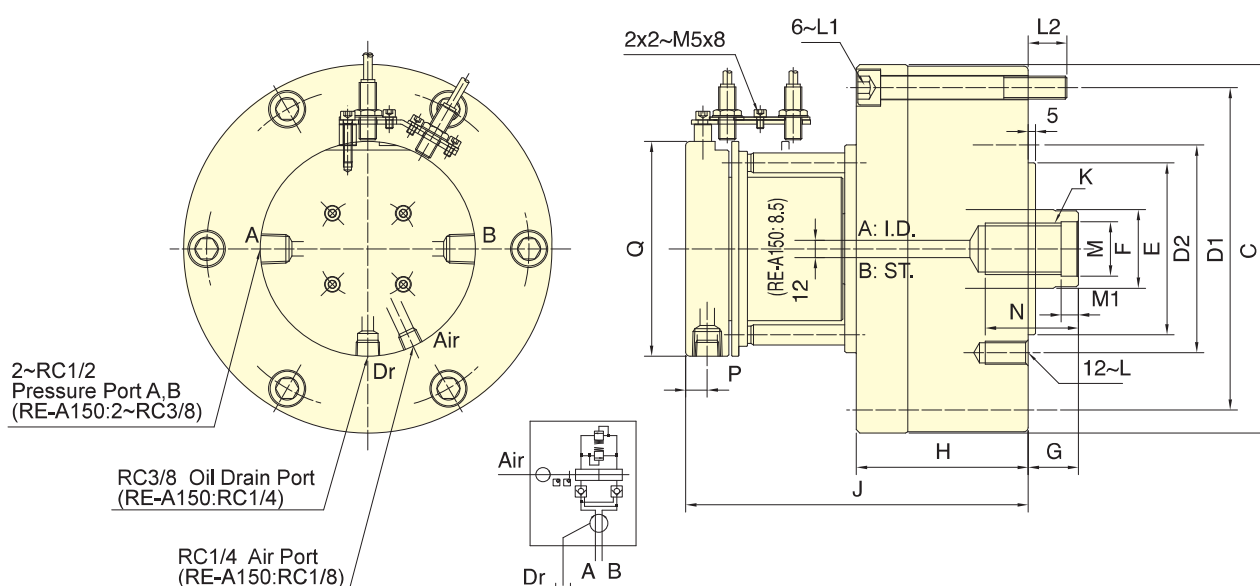

Subject to technical changes

SPECIFICATIONS

Model	Eff. piston area		Piston stroke	Max. speed	Max. pressure	Coolant connection Max. pressure	I		Weight
	Extend	Retract					Moment of inertia	kg·m ²	
	cm ²	cm ²							
RE-A150	174.4	160.8	30	5500	4.0(40)	0.8(8)	0.06	14.9	
RE-A200K	292.4	274.9	35	4000	4.0(40)	0.8(8)	0.19	29.1	
RE-A200L	292.4	265.4	50	4000	5.0(50)	0.8(8)	0.21	30.4	
RE-A250	465.2	438.2	60	2000	5.0(50)	0.8(8)	0.43	47.2	

DIMENSIONS

Model	A	B	C	D1	D2	E (h7)	F	G max.	G min.	H	J	K	L	L1	L2	M (H8)	M1	N	P	Q
RE-A150	150	30	205	180	130	110	45	60	30	99	177.5	M30x3.5	M12x24	M12x105	18.5	32	10	50	12.5	114
RE-A200K	195	35	257	225	145	120	55	73	38	120	239	M36x4.0	M16x30	M16x130	27	38	12	65	15	150
RE-A200L	195	50	257	225	170	125	65	80	30	135	254	M42x3.0	M16x30	M16x145	27	45	12	65	15	150
RE-A250	245	60	307	275	220	160	65	85	25	165	280	M42x3.0	M20x35	M16x175	28	45	12	65	15	150

Proximity sensor : Model IFS287(IFM) DC 10-30V 100mA NPN .



- For short form, light weight and high speed rotary cylinder. To allow coolant to be feed from the rear end of the distributor through the rotating union.
- Built-in safety check valves, pressure relief valves and proximity sensor.
- Can screw it from the rear end of the cylinder when mounting.
- The drain port should be independently connected to oil tank to avoid back pressure.

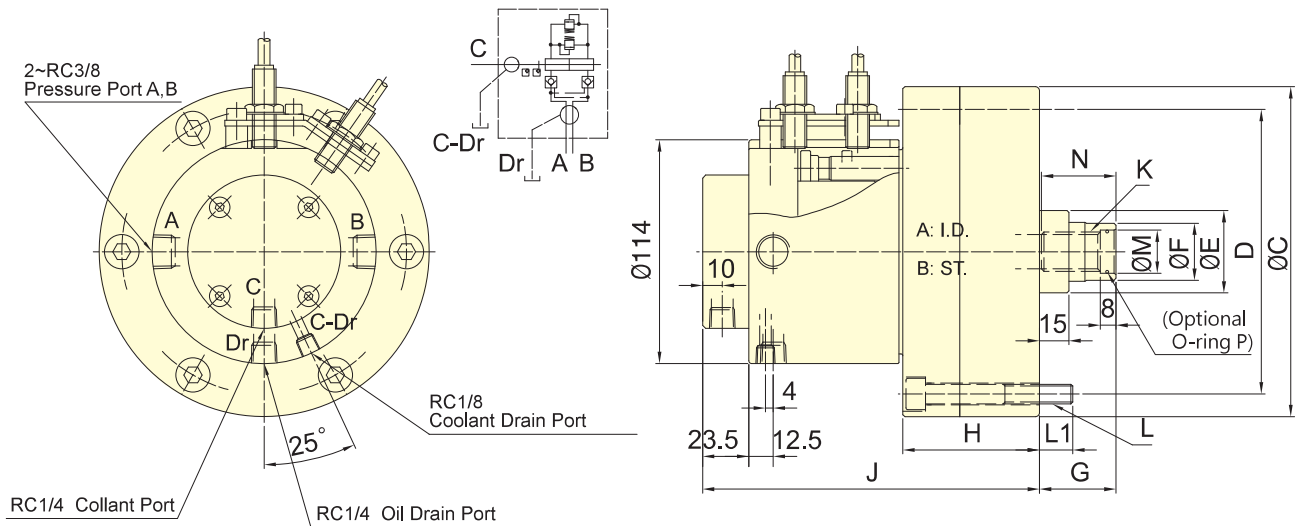

Subject to technical changes

SPECIFICATIONS

Model	Eff. piston area		Piston stroke	Max. speed	Max. pressure	Coolant connection Max. pressure	I	Weight
	Extend	Retract						
	cm ²	cm ²					mm	
RE-L110	92.7	87.9	20	6000	4.0(40)	1.5(15)	0.02	7.2
RE-L120	110.8	106	21	6000	4.0(40)	1.5(15)	0.03	9.1
RE-L130	128.9	123.1	30	6000	4.0(40)	1.5(15)	0.03	9.5

DIMENSIONS

Model	A	B	C (h7)	D	E	F	G max.	G min.	H	J	K	L	L1	M (H8)	N	P
RE-L110	110	20	145	128	42	29	60	40	66	169.5	M20x2.5	6~M8x70	12	22	38	S20
RE-L120	120	21	168	145	42	29	60	39	69.5	171.5	M20x2.5	6~M10x75	17	22	38	S20
RE-L130	130	30	168	150	50	33	60	30	79.5	181.5	M24x3.0	6~M10x85	17	27	43	S24

Proximity sensor : Model IFS287(IFM) DC 10-30V 100mA NPN .



- For short form, light weight and high speed rotary cylinder. To allow coolant to be feed from the rear end of the distributor through the rotating union, suitable for vertical lathe.
- Built-in safety check valves, pressure relief valves and proximity sensor.
- Can screw it from the rear end of the cylinder when mounting.
- The drain port should be independently connected to oil tank to avoid back pressure.

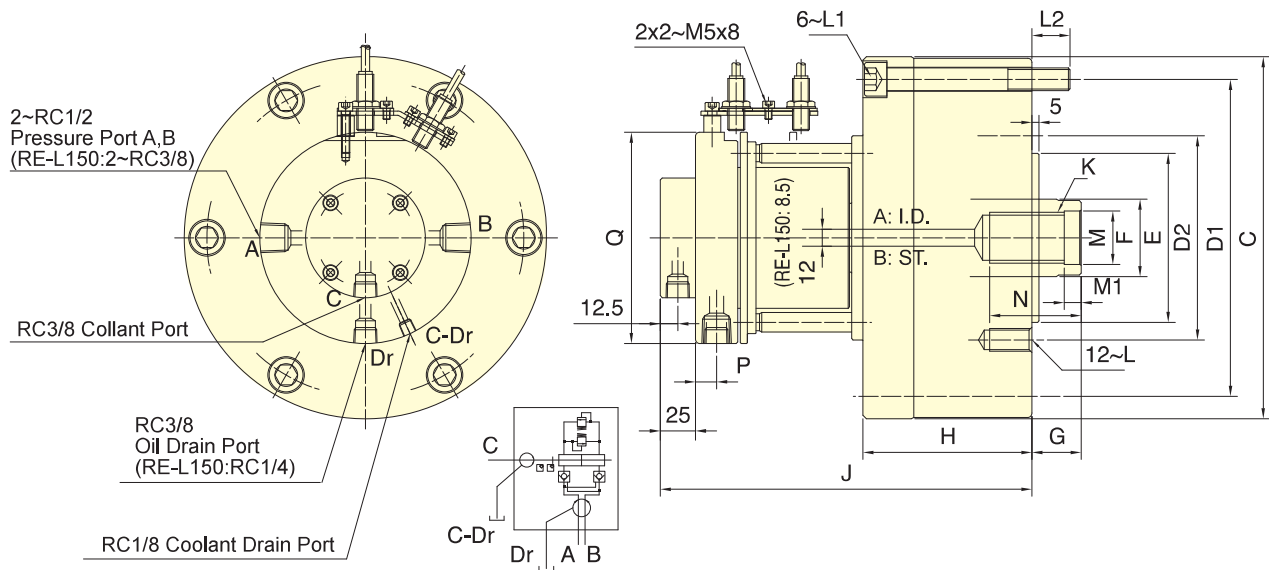

Subject to technical changes

SPECIFICATIONS

Model	Eff. piston area		Piston stroke	Max. speed	Max. pressure	Coolant connection Max. pressure	I	
	Extend	Retract					Moment of inertia	Weight
	cm ²	cm ²						
RE-L150	174.4	160.8	30	5500	4.0(40)	1.5(15)	0.06	15.2
RE-L200K	292.4	274.9	35	4000	4.0(40)	1.5(15)	0.19	29.4
RE-L200L	292.4	265.4	50	4000	5.0(50)	1.5(15)	0.21	30.7
RE-L250	465.2	438.2	60	2000	5.0(50)	1.5(15)	0.43	47.5

DIMENSIONS

Model	A	B	C	D1	D2	E (h7)	F	G max.	G min.	H	J	K	L	L1	L2	M (H8)	M1	N	P	Q
RE-L150	150	30	205	180	130	110	45	60	30	99	201	M30x3.5	M12x24	M12x105	18.5	32	10	50	12.5	114
RE-L200K	195	35	257	225	145	120	55	73	38	120	264	M36x4.0	M16x30	M16x130	27	38	12	65	15	150
RE-L200L	195	50	257	225	170	125	65	80	30	135	279	M42x3.0	M16x30	M16x145	27	45	12	65	15	150
RE-L250	245	60	307	275	220	160	65	85	25	165	305	M42x3.0	M20x35	M16x175	28	45	12	65	15	150

Proximity sensor : Model IFS287(IFM) DC 10-30V 100mA NPN .

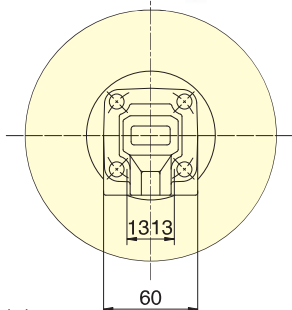

Subject to technical changes

SPECIFICATIONS

Model	Eff. piston area				Piston stroke mm	Max. speed min ⁻¹ (r.p.m.)	Max. pressure MPa(kgf/cm ²)	I Moment of inertia kg·m ²	Weight kg
	Extend		Retract						
	A cm ²	B cm ²	A cm ²	B cm ²					
RD-120	122.7	126.1	116.1	113.1	20	5000	3.0(30)	0.14	11.3
RD-125	122.7	126.1	116.1	113.1	25	5000	3.0(30)	0.15	11.5

DIMENSIONS

Model	A	B	C	D	E max.	E min.	F max.	F min.
RD-120	125	130	137	227	60	40	35	15
RD-125	125	130	147	237	55	30	35	10

- For short form, light weight, double rod rotary cylinder.
- Built-in safety check valves and pressure relief valves.
- The drain port should be independently connected to oil tank to avoid back pressure.

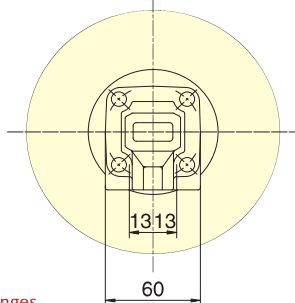
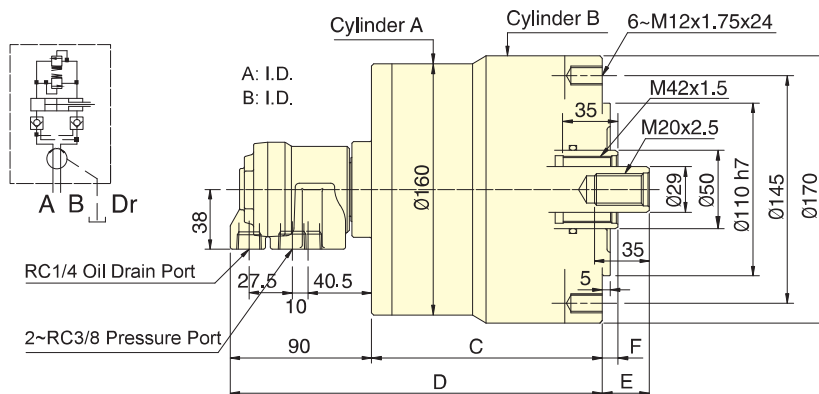

Subject to technical changes

SPECIFICATIONS

Model	Eff. piston area				Piston stroke mm	Max. speed min ⁻¹ (r.p.m.)	Max. pressure MPa(kgf/cm ²)	I Moment of inertia kg·m ²	Weight kg
	Extend		Retract						
	A cm ²	B cm ²	A cm ²	B cm ²					
RD-120N	122.7	126.1	116.1	113.1	20	5000	3.0(30)	0.14	11.2
RD-125N	122.7	126.1	116.1	113.1	25	5000	3.0(30)	0.15	11.4

DIMENSIONS

Model	A	B	C	D	E max.	E min.	F max.	F min.
RD-120N	125	130	137	214	60	40	35	15
RD-125N	125	130	147	224	55	30	35	10

- For short form, light weight, double rod rotary cylinder.
- The drain port should be independently connected to oil tank to avoid back pressure.

