

TPHK Series

Immersible Pump



TPHK Series Immersible Pump



50Hz

Power: 0.34 - 3.8 kW

Head: Up to 65M

Flow: Up to 280 L/min

60Hz

Power: 0.37 - 4.15 kW

Head: Up to 90M

Flow: Up to 280 L/min

Outlet: 3/4" - 1 1/4"

Applications

The TPHK Series is vertical multistage centrifugal pump, designed for industrial use, specially for machine tools. It is suitable to carry fluids such as water, coolant, light oil and other clean, non aggressive matters:

- Industrial circulation system
- Washing/cleaning system
- Filtration system

Operating Conditions

1. Ambient temperature : Max. +40°C
2. Liquid temperature range : +0°C ~ +90°C
3. Operating pressure : Max. 10 kg/cm²
4. Submerged depth : Min. 40mm

Model code

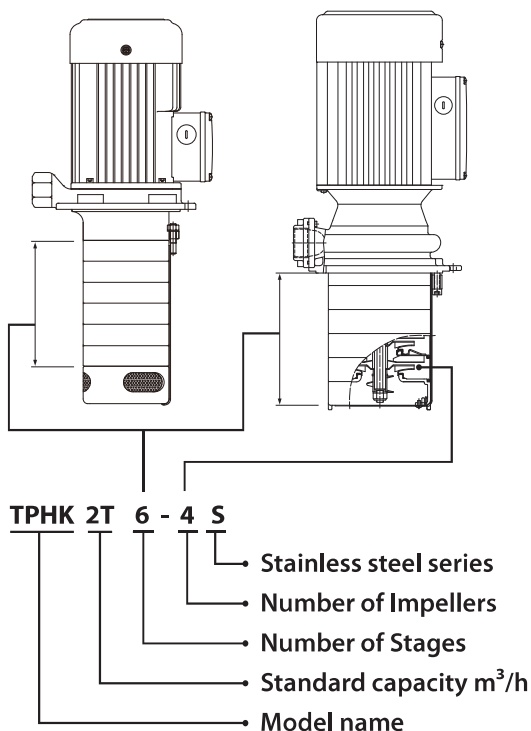

Pump Construction

Immersible vertical multistage centrifugal pump, self-priming, co-axial pump/motor design, impellers mounted on extended motor shaft. Main working parts made by stainless steel.

Motor

Enclosure class : IP54

Insulation class : F.

Nominal speed : 2900 / 3500 rpm

Frequency range : 50 / 60 Hz

Voltages Code :

| Code | PH | 50Hz | 60Hz |
|------|----|------------------|------------------|
| 53Q | 3 | 200-240/380-440V | - |
| A3Z* | 3 | 200-255/380-440V | 200-255/380-480V |
| A3U* | 3 | 200-240/380-415V | 200-240/380-440V |

* The motor can be use in both 50/60 hz.

TPHK Series Immersible Pump

Performance curve (50Hz)

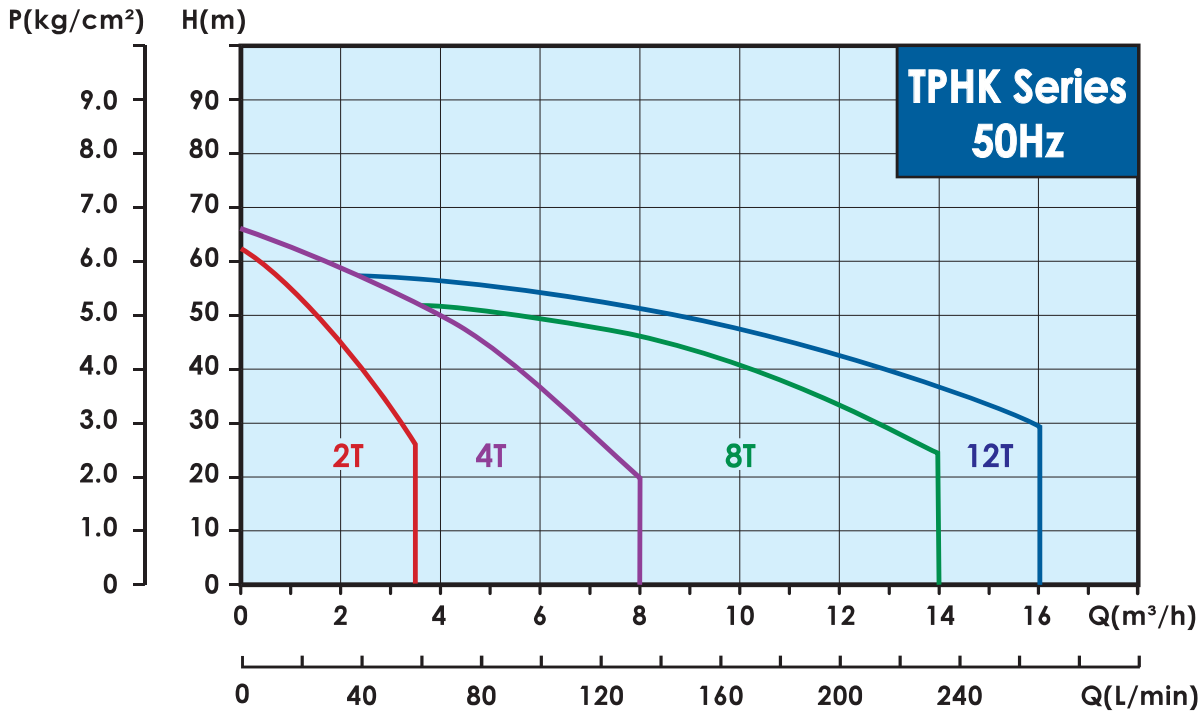

Performance curve (60Hz)

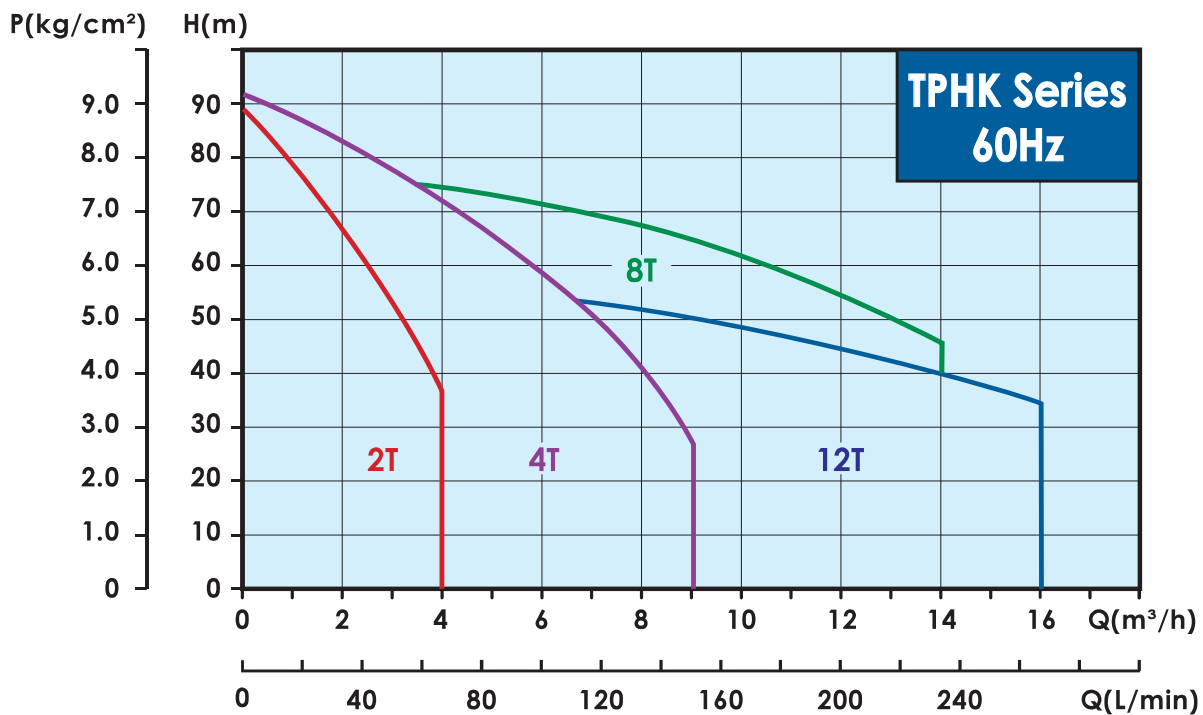

Sectional drawing

TPHK 2T/4T

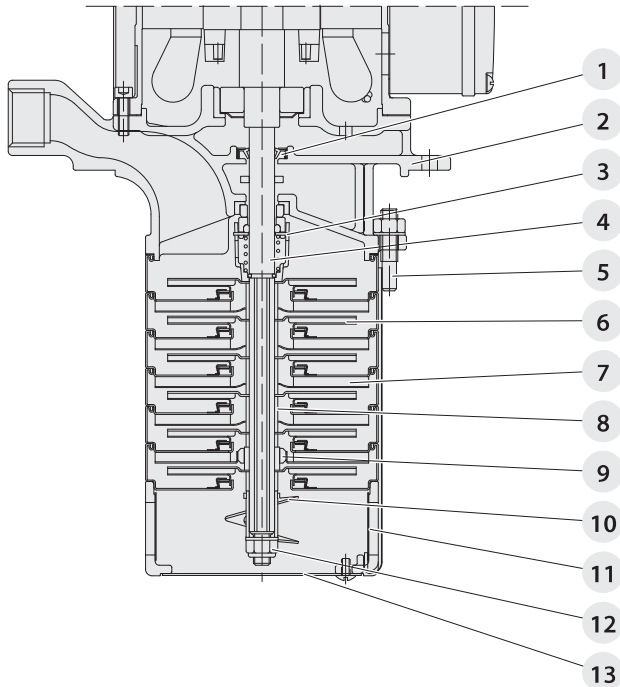

Materials

| NO. | Part name | Material | |
|-----|-------------------------|----------|----------|
| | | Standard | S series |
| 1 | Oil Seal | NBR | |
| 2 | Pump Casing | FCD 45 | SUS 304 |
| 3 | Mechanical Seal | HSSH | HGSH |
| 4 | Shaft | SUS 304 | |
| 5 | Strap | SUS 304 | |
| 6 | Impeller | SUS 304 | |
| 7 | Intermediate chamber | SUS 304 | |
| 8 | Sleeve | SUS 304 | |
| 9 | Bearing | SiC | |
| 10 | Priming screw | SUS 304 | |
| 11 | Suction intercon-necter | SUS 304 | |
| 12 | Lock Nut | SUS 316 | |
| 13 | Filter | SUS 304 | |
| 14 | Flange | SUS 304 | |

TPHK 8T/12T

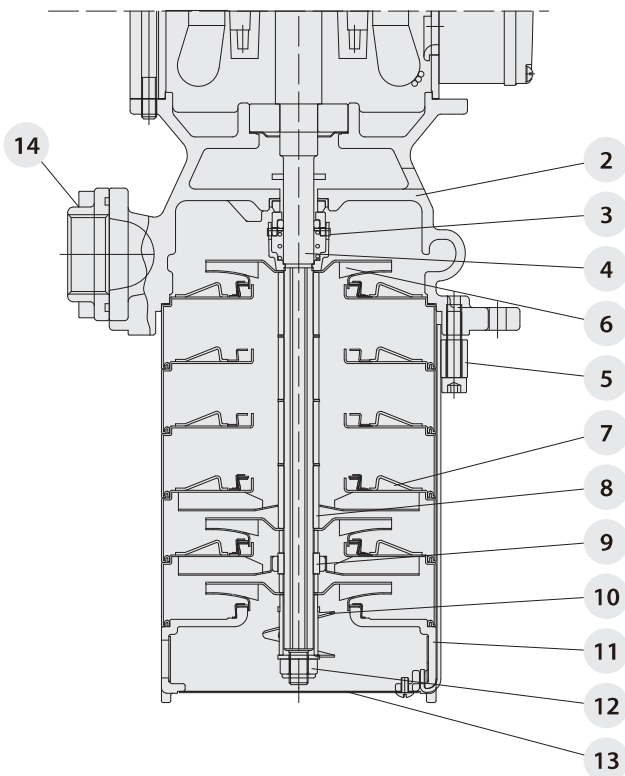

Options on request

- Special mechanical seal

| Mechanical seal type | Material | |
|----------------------|---|------------------------|
| | Stationary Face/ Rotary Face | Cup Gasket & O Ring |
| HGSH HGSV HGSE | (G)Carbon/ (S)Silicium carbide | (H) HNBR (V) Viton |
| HSSH HSSV HSSE | (S)Silicium carbide/ (S)Silicium carbide | (E) EPDM |

TPHK 4T

Electrical data

| Standard Model | Phase (Ø) | Voltage code | Cycle (Hz) | Volts (V) | Input Power (W) | Input Ampere (A) |
|----------------|-----------|--------------|------------|-------------------|-----------------|--------------------|
| TPHK 4T 2 - 1 | 3 | A3Z | 50 | 200-255 / 380-440 | 570 | 1.9-2.8 / 1.2-1.7 |
| | | | 60 | 200-255 / 380-480 | 600 | 2.3-2.3 / 1.4-1.4 |
| TPHK 4T 2 - 2 | 3 | A3Z | 50 | 200-255 / 380-440 | 650 | 2.2-2.9 / 1.4-1.7 |
| | | | 60 | 200-255 / 380-480 | 960 | 3.0-2.7 / 1.7-1.7 |
| TPHK 4T 3 - 3 | 3 | A3Z | 50 | 200-255 / 380-440 | 850 | 3.1-3.6 / 1.8-2.1 |
| | | | 60 | 200-255 / 380-480 | 1290 | 4.0-3.6 / 2.4-2.4 |
| TPHK 4T 4 - 4 | 3 | A3U | 50 | 200-240 / 380-415 | 1080 | 3.4-3.5 / 2.0-2.0 |
| | | | 60 | 200-240 / 380-440 | 1620 | 4.5-5.0 / 2.9-2.9 |
| TPHK 4T 5 - 5 | 3 | A3U | 50 | 200-240 / 380-415 | 1440 | 4.9-6.8 / 3.0-3.8 |
| | | | 60 | 200-240 / 380-440 | 2100 | 6.2-6.0 / 3.5-3.5 |
| TPHK 4T 6 - 6 | 3 | A3U | 50 | 200-240 / 380-415 | 1740 | 6.3-9.9 / 4.2-5.5 |
| | | | 60 | 200-240 / 380-440 | 2400 | 7.7-7.6 / 4.5-4.5 |
| TPHK 4T 7 - 7 | 3 | A3U | 50 | 200-240 / 380-415 | 2140 | 6.9-10.3 / 4.5-5.8 |
| | | | 60 | 200-240 / 380-440 | 2800 | 8.7-8.4 / 4.9-4.9 |

Maximum 8 Stages

Dimensions (mm)

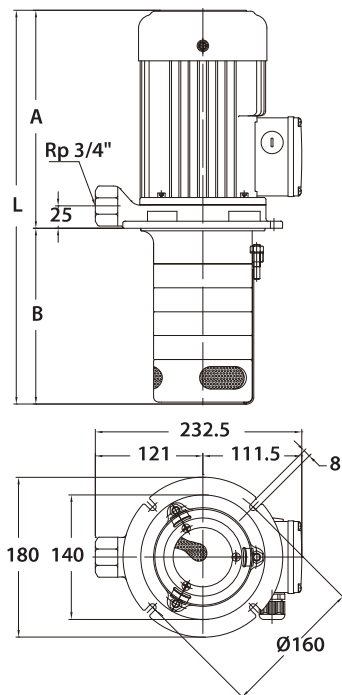

| Model | A (mm) 50Hz / 60Hz | B (mm) | L (mm) 50Hz / 60Hz | N.W.(kg) |  |
|---------------|-----------------------|--------|-----------------------|----------|---|
| TPHK 4T 2 - 1 | 205.5 | 144 | 349.5 | 10.8 | 30 |
| TPHK 4T 3 - 1 | 205.5 | 171 | 376.5 | 11.0 | 30 |
| TPHK 4T 2 - 2 | 205.5 | 144 | 349.5 | 11.0 | 30 |
| TPHK 4T 3 - 2 | 205.5 | 171 | 376.5 | 11.2 | 30 |
| TPHK 4T 4 - 2 | 205.5 | 198 | 403.5 | 11.4 | 30 |
| TPHK 4T 6 - 2 | 205.5 | 252 | 457.5 | 11.6 | 24 |
| TPHK 4T 3 - 3 | 245.5 | 171 | 416.5 | 11.7 | 30 |
| TPHK 4T 4 - 3 | 245.5 | 198 | 443.5 | 11.9 | 30 |
| TPHK 4T 5 - 3 | 245.5 | 225 | 470.5 | 12.1 | 30 |
| TPHK 4T 6 - 3 | 245.5 | 252 | 497.5 | 12.3 | 24 |
| TPHK 4T 8 - 3 | 245.5 | 306 | 551.5 | 12.7 | 24 |
| TPHK 4T 4 - 4 | 245.5 | 198 | 443.5 | 13.3 | 30 |
| TPHK 4T 5 - 4 | 245.5 | 225 | 470.5 | 13.5 | 30 |
| TPHK 4T 6 - 4 | 245.5 | 252 | 497.5 | 13.7 | 24 |
| TPHK 4T 5 - 5 | 245.5 | 225 | 470.5 | 13.9 | 30 |
| TPHK 4T 8 - 5 | 245.5 | 306 | 551.5 | 14.5 | 24 |
| TPHK 4T 6 - 6 | 253 / 284.5 | 252 | 506 / 536.5 | 14.1 | 24 |
| TPHK 4T 8 - 6 | 253 / 284.5 | 306 | 560 / 590.5 | 14.6 | 24 |
| TPHK 4T 7 - 7 | 284.5 | 279 | 563.5 | 14.6 | 24 |
| TPHK 4T 8 - 7 | 284.5 | 306 | 590.5 | 14.8 | 24 |

Performance curve (50Hz)

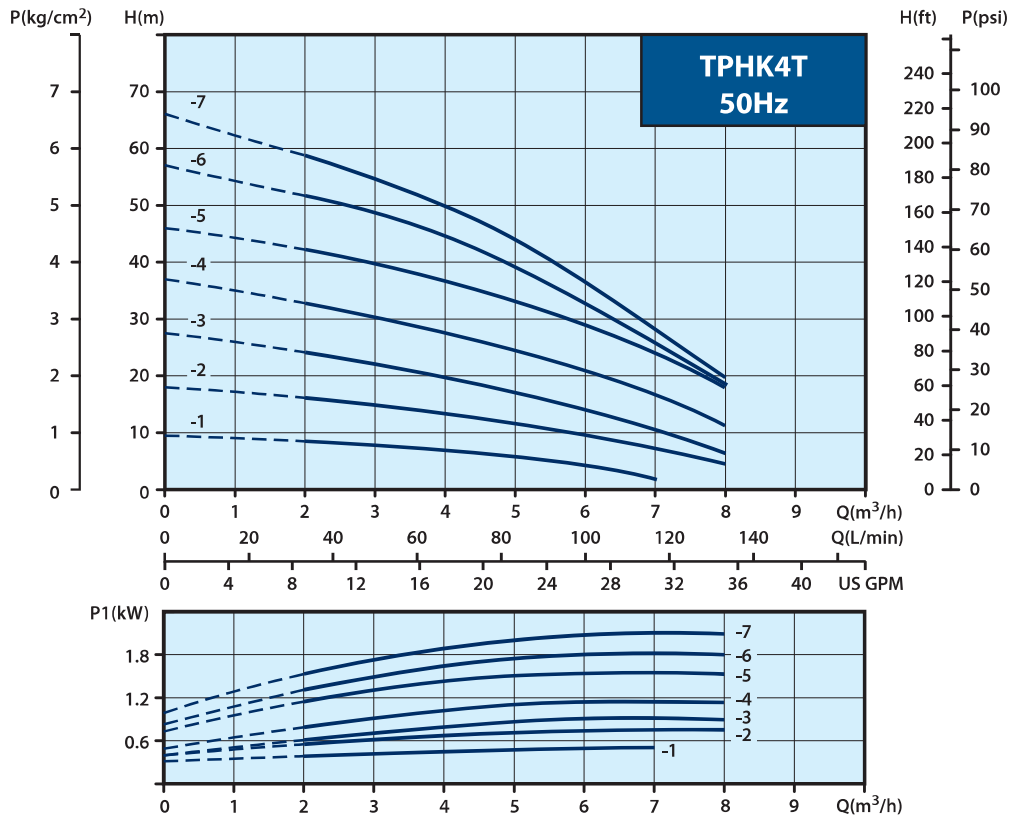

Performance curve (60Hz)

